

SUPER AUDIO CD PLAYER

CD-S1000

CD-S1000

SERVICE MANUAL

IMPORTANT NOTICE

This manual has been provided for the use of authorized YAMAHA Retailers and their service personnel.

It has been assumed that basic service procedures inherent to the industry, and more specifically YAMAHA Products, are already known and understood by the users, and have therefore not been restated.

WARNING: Failure to follow appropriate service and safety procedures when servicing this product may result in personal injury, destruction of expensive components, and failure of the product to perform as specified. For these reasons, we advise all YAMAHA product owners that any service required should be performed by an authorized YAMAHA Retailer or the appointed service representative.

IMPORTANT: The presentation or sale of this manual to any individual or firm does not constitute authorization, certification or recognition of any applicable technical capabilities, or establish a principle-agent relationship of any form.

The data provided is believed to be accurate and applicable to the unit(s) indicated on the cover. The research, engineering, and service departments of YAMAHA are continually striving to improve YAMAHA products. Modifications are, therefore, inevitable and specifications are subject to change without notice or obligation to retrofit. Should any discrepancy appear to exist, please contact the distributor's Service Division.

WARNING: Static discharges can destroy expensive components. Discharge any static electricity your body may have accumulated by grounding yourself to the ground buss in the unit (heavy gauge black wires connect to this buss).

IMPORTANT: Turn the unit OFF during disassembly and part replacement. Recheck all work before you apply power to the unit.

■ CONTENTS

TO SERVICE PERSONNEL	2-3	DISPLAY DATA	25
PREVENTION OF ELECTROSTATIC DISCHARGE	4	IC DATA	26-28
FRONT PANEL	5	PIN CONNECTION DIAGRAMS	29-30
REAR PANELS	5-7	BLOCK DIAGRAM	31
REMOTE CONTROL PANEL	8	PRINTED CIRCUIT BOARDS	32-40
SPECIFICATIONS / 参考仕様	8-9	SCHEMATIC DIAGRAMS	41-45
INTERNAL VIEW	9	REPLACEMENT PARTS LIST	47-56
DISASSEMBLY PROCEDURES / 分解手順	10-16	REMOTE CONTROL	57
TEST MODE / テストモード	17		
UPDATING FIRMWARE / ファームウェアの書き込み	18-24		



このサービスマニュアルは、エコマーク認定の再生紙を使用しています。
This Service Manual uses recycled paper.

101092

Copyright © 2008 YAMAHA CORPORATION All rights reserved.
This manual is copyrighted by YAMAHA and may not be copied or
redistributed either in print or electronically without permission.



YAMAHA

YAMAHA CORPORATION
P.O.Box 1, Hamamatsu, Japan

08.05

■ TO SERVICE PERSONNEL

1. Critical Components Information
Components having special characteristics are marked  and must be replaced with parts having specifications equal to those originally installed.
2. Leakage Current Measurement (For 120V Models Only)
When service has been completed, it is imperative to verify that all exposed conductive surfaces are properly insulated from supply circuits.
 - Meter impedance should be equivalent to 1500 ohms shunted by 0.15 μ F.

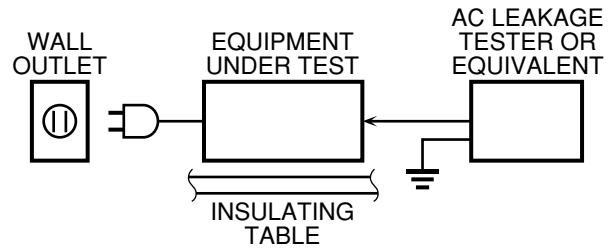

- Leakage current must not exceed 0.5mA.
- Be sure to test for leakage with the AC plug in both polarities.

WARNING: CHEMICAL CONTENT NOTICE!

This product contains chemicals known to the State of California to cause cancer, or birth defects or other reproductive harm.

DO NOT PLACE SOLDER, ELECTRICAL/ELECTRONIC OR PLASTIC COMPONENTS IN YOUR MOUTH FOR ANY REASON WHAT SO EVER!

Avoid prolonged, unprotected contact between solder and your skin! When soldering, do not inhale solder fumes or expose eyes to solder/flux vapor!

If you come in contact with solder or components located inside the enclosure of this product, wash your hands before handling food.

About lead free solder / 無鉛ハンダについて

All of the P.C.B.s installed in this unit and solder joints are soldered using the lead free solder.

Among some types of lead free solder currently available, it is recommended to use one of the following types for the repair work.

- Sn + Ag + Cu (tin + silver + copper)
- Sn + Cu (tin + copper)
- Sn + Zn + Bi (tin + zinc + bismuth)

Caution:

As the melting point temperature of the lead free solder is about 30°C to 40°C (50°F to 70°F) higher than that of the lead solder, be sure to use a soldering iron suitable to each solder.

本機に搭載されているすべての基板およびハンダ付けによる接合部は無鉛ハンダでハンダ付けされています。

無鉛ハンダにはいくつかの種類がありますが、修理時には下記のような無鉛ハンダの使用を推奨します。

- Sn+Ag+Cu(錫+銀+銅)
- Sn+Cu(錫+銅)
- Sn+Zn+Bi(錫+亜鉛+ビスマス)

注意：

無鉛ハンダの融点温度は通常の鉛入りハンダに比べ30~40°C程度高くなっていますので、それぞれのハンダに合ったハンダごてをご使用ください。

WARNING: Laser Safety

This product contains a laser beam component. This component may emit invisible, as well as visible radiation, which may cause eye damage. To protect your eyes and skin from laser radiation, the following precautions must be used during servicing of the unit.

- 1) When testing and/or repairing any component within the product, keep your eyes and skin more than 30 cm away from the laser pick-up unit at all times. Do not stare at the laser beam at any time.
- 2) Do not attempt to readjust, disassemble or repair the laser pick-up, unless noted elsewhere in this manual.
- 3) CAUTION : Use of controls, adjustments or performance of procedures other than those specified herein may result in hazardous radiation exposure.

Laser Emitting conditions:

- 1) When the top cover is removed, and the STANDBY/ON SW is turned to the "ON" position, the laser component will emit a beam for several seconds to detect if a disc is present. During this time (5-10 sec.) the laser may radiate through the lens of the laser pick-up unit. Do not attempt any servicing during this period!
If no disc is detected, the laser will stop emitting the beam. When a disc is loaded, you will not be exposed to any laser emissions.
- 2) The laser power level can be adjusted with the VR on the pick-up PWB, however, this level has been set by the factory prior to shipping from the factory. Do not adjust this laser level control unless instruction is provided elsewhere in this manual. Adjustment of this control can increase the laser emission level from the device.

Laser Diode Properties

- | | | | | | |
|----------------------|-------|-------------------------------|------------------------|-------|-------------|
| • Material: | SA-CD | Semiconductor laser (AlGaInP) | • Laser Output: | SA-CD | 5 mW (max.) |
| | CD | Semiconductor laser (AlGaAs) | | CD | 7 mW (max.) |
| • Wavelength: | SA-CD | 650 nm | | | |
| | CD | 780 nm | | | |

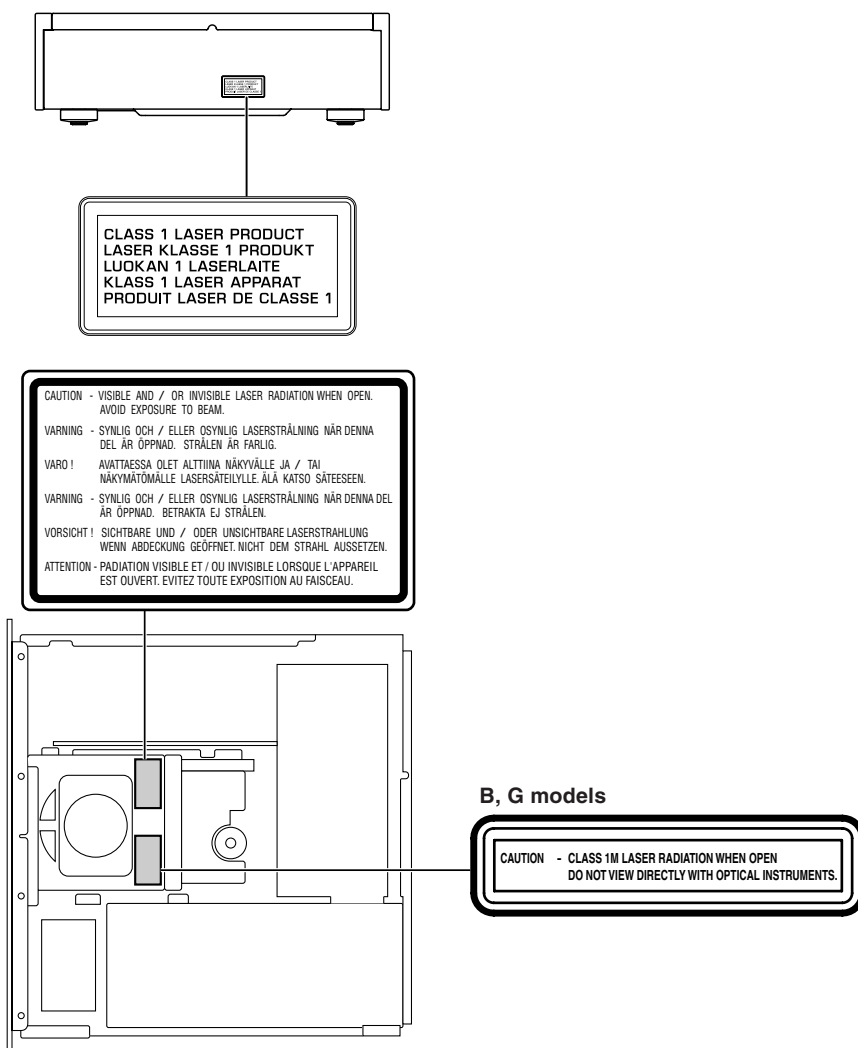

Warning for power supply

The primary side of the power supply carries live mains voltage when the player is connected to the mains even when the player is switched off !

This primary area is not shielded so it is possible to accidentally touch copper tracks and/or components when servicing the player.

Service personnel have to take precautions to prevent touching this area or components in this area.

Note:

The screws on the DVD mechanism may never be touched, removed or re-adjusted.

Handle the DVD mechanism with care when the unit has to be exchanged!

The DVD mechanism is very sensitive for dropping or giving shocks.

■ PREVENTION OF ELECTROSTATIC DISCHARGE

Some semiconductor (solid state) devices can be damaged easily by static electricity. Such components commonly are called Electrostatically Sensitive (ES) Devices. Examples of typical ES devices are integrated circuits and some field-effect transistors and semiconductor “chip” components. The following techniques should be used to help reduce the incidence of component damage caused by electro static discharge (ESD).

1. Immediately before handling any semiconductor component or semiconductor-equipped assembly, drain off any ESD on your body by touching a known earth ground. Alternatively, obtain and wear a commercially available discharging ESD wrist strap, which should be removed for potential shock reasons prior to applying power to the unit under test.
2. After removing an electrical assembly equipped with ES devices, place the assembly on a conductive surface such as aluminum foil, to prevent electrostatic charge buildup or exposure of the assembly.
3. Use only a grounded-tip soldering iron to solder or unsolder ES devices.
4. Use only an anti-static solder removal device. Some solder removal devices not classified as “anti-static (ESD protected)” can generate electrical charge sufficient to damage ES devices.
5. Do not use freon-propelled chemicals. These can generate electrical charges sufficient to damage ES devices.
6. Do not remove a replacement ES device from its protective package until immediately before you are ready to install it. (Most replacement ES devices are packaged with leads electrically shorted together by conductive foam, aluminum foil or comparable conductive material).
7. Immediately before removing the protective material from the leads of a replacement ES device, touch the protective material to the chassis or circuit assembly into which the device will be installed.
CAUTION: Be sure no power is applied to the chassis or circuit, and observe all other safety precautions.
8. Minimize bodily motions when handling unpackaged replacement ES devices. (Otherwise harmless motion such as brushing together of your fabric clothes or lifting of your foot from a carpeted floor can generate static electricity (ESD) sufficient to damage an ES device).

Grounding for electrostatic breakdown prevention

1. Human body grounding.
Use the antistatic wrist strap to discharge the static electricity from your body.
2. Work table grounding.
Put a conductive material (sheet) or steel sheet on the area where the optical pickup is placed and ground the sheet.

Caution:

The static electricity of your clothes will not be grounded through the wrist strap. So take care not to let your clothes touch the optical pickup.

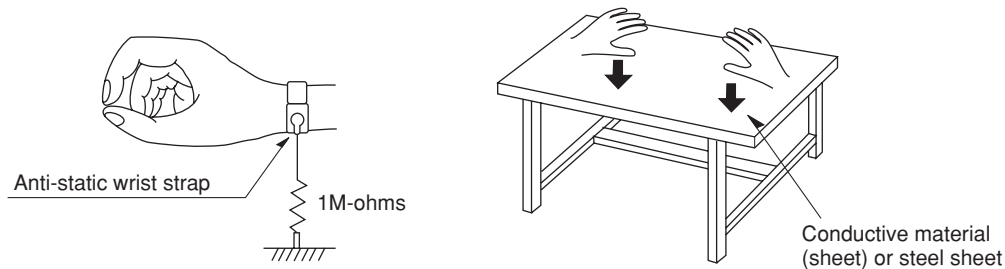

FRONT PANEL

CD-S1000 (U, C, R, T, K, A, B, G, L, J models)

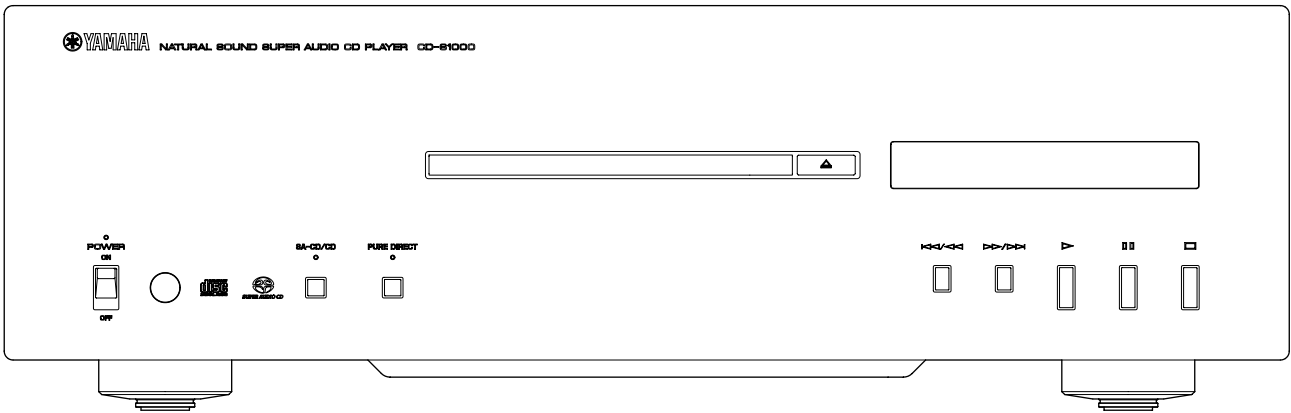

REAR PANELS

CD-S1000 (U, C models)

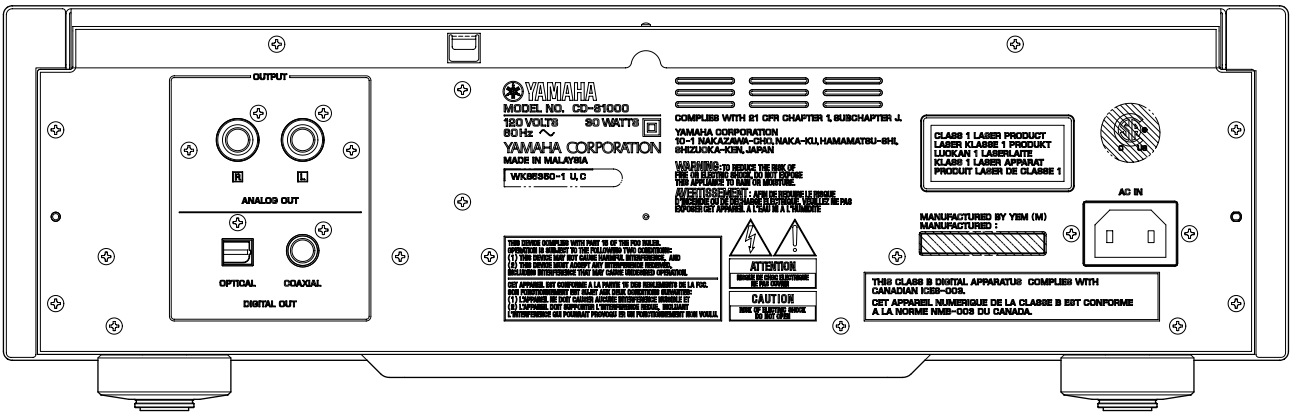

CD-S1000 (R model)

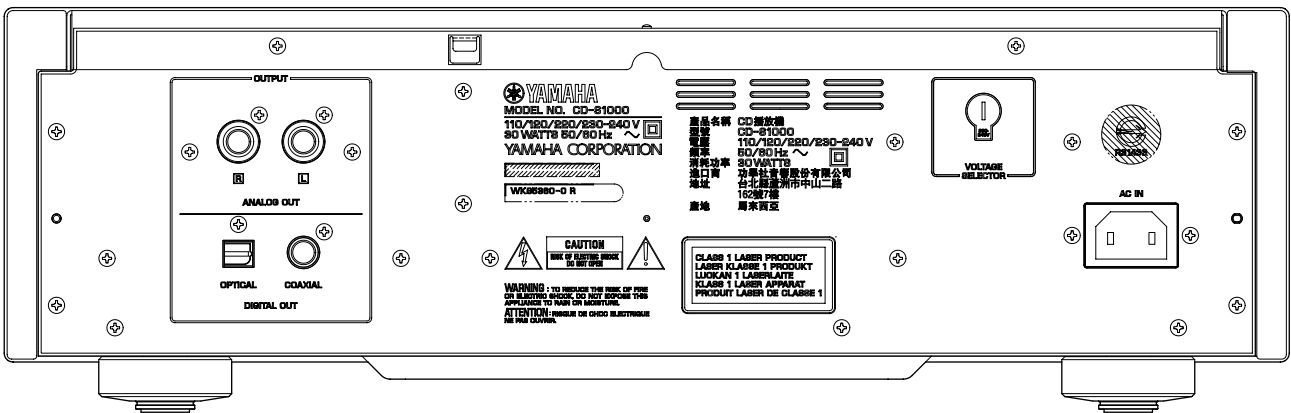

CD-S1000 (T model)

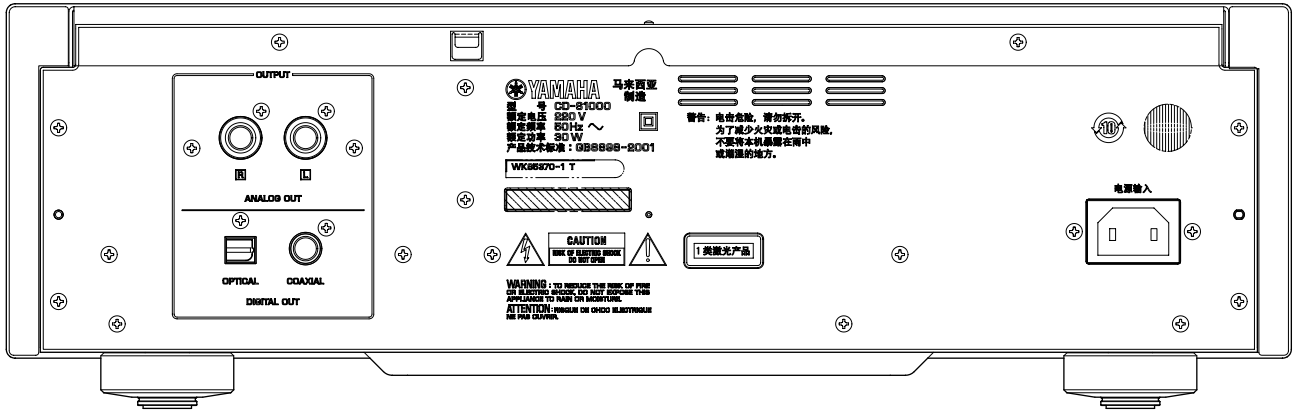

CD-S1000 (K model)

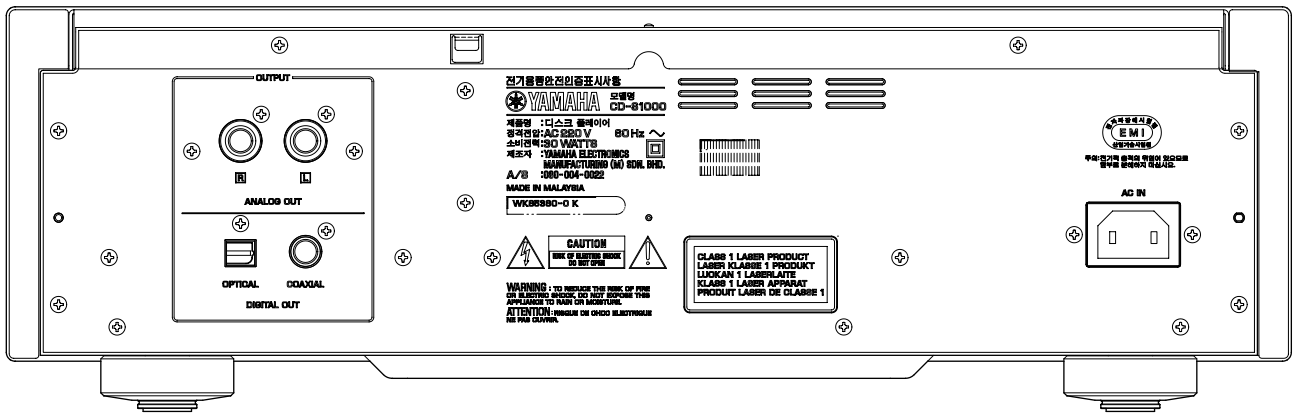

CD-S1000 (A model)

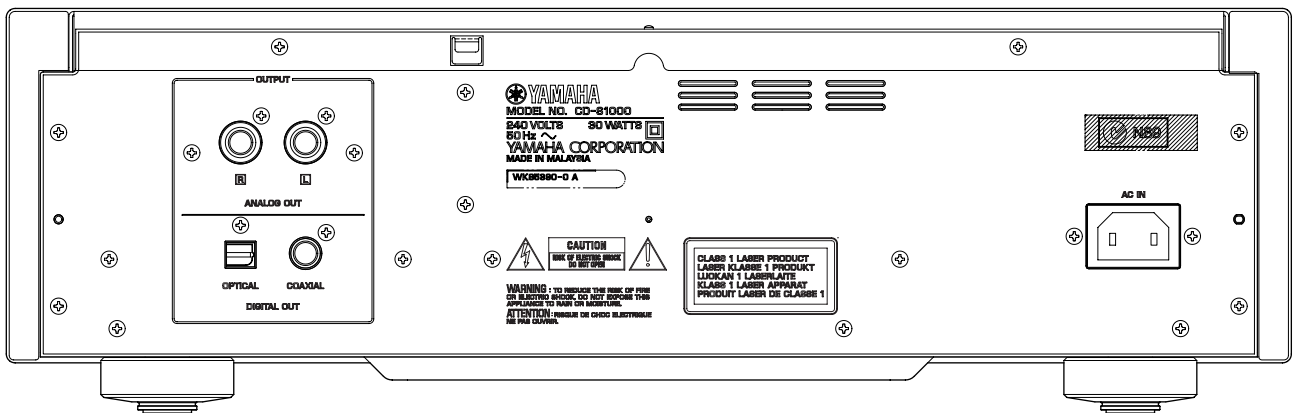

CD-S1000 (B, G models)

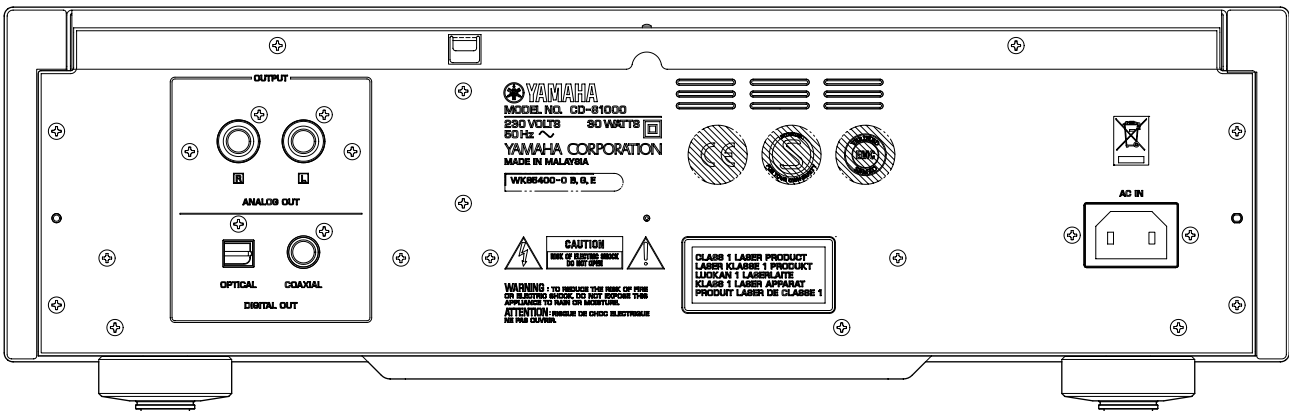

CD-S1000 (L model)

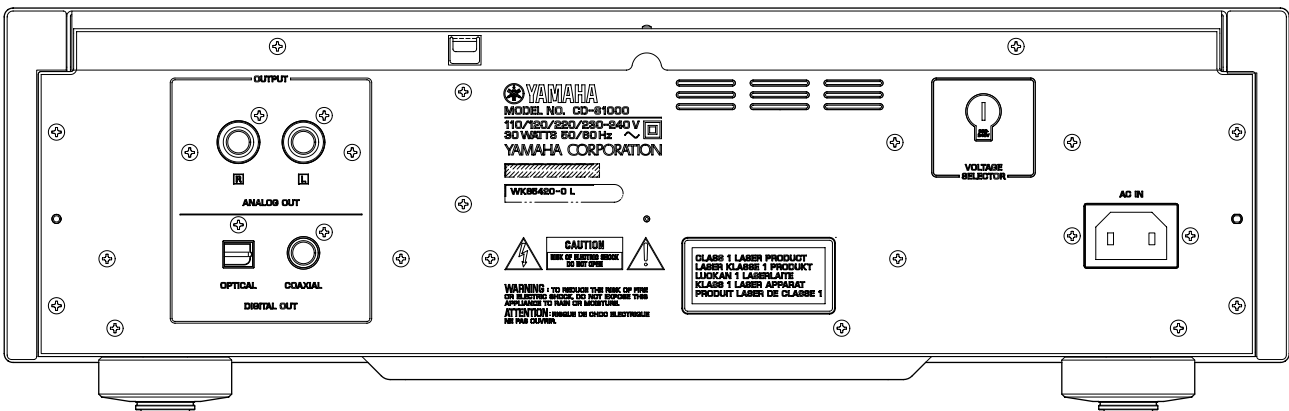

CD-S1000 (J model)

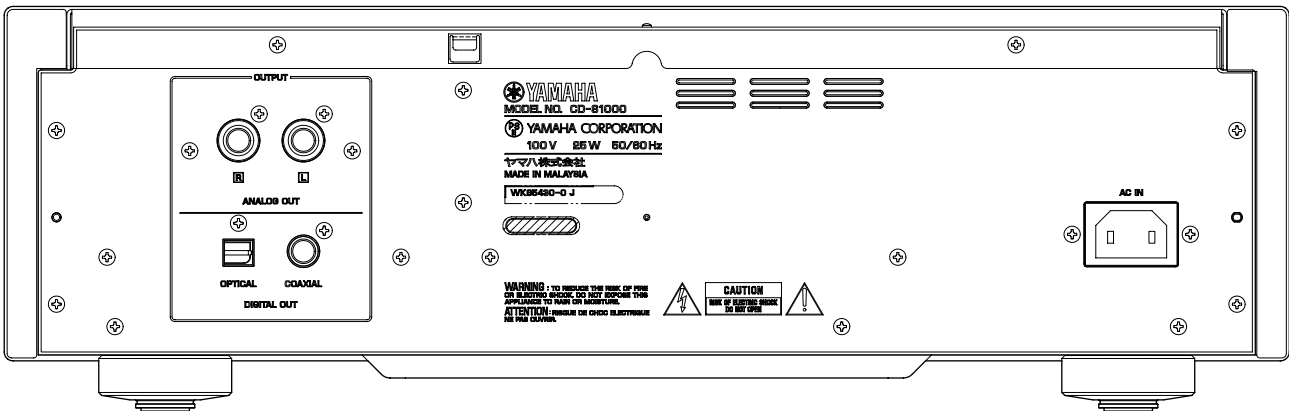

REMOTE CONTROL PANEL

CDX5

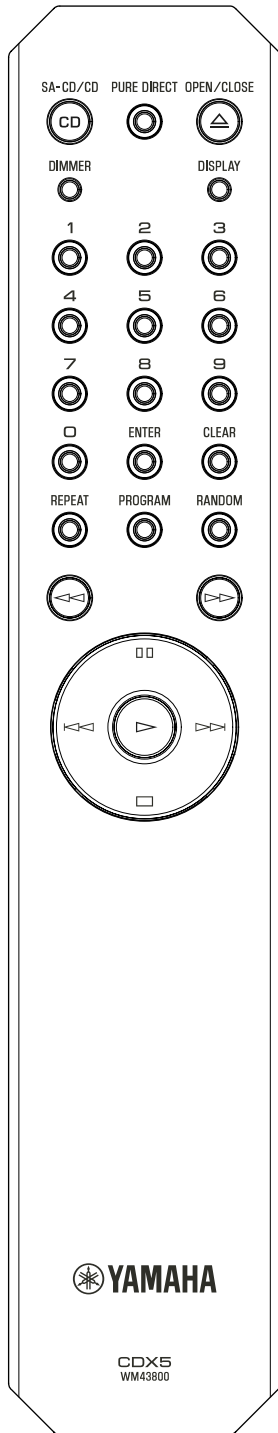

SPECIFICATIONS / 参考仕様

Audio Section / オーディオ部

Frequency Response / 周波数特性

SA-CD 2 Hz to 50 kHz (-3 dB)
 CD 2 Hz to 20 kHz

Total Harmonic Distortion (1 kHz) / 高調波歪率(1 kHz)

..... 0.002 % or less

Signal to Noise Ratio / 信号対雑音比 (IHF-A Network)

..... 113 dB or more

Dynamic Range / ダイナミックレンジ

SA-CD 105 dB or more
 CD 100 dB or more

Output Level (1 kHz, 0 dB) / 出力レベル(1 kHz、0 dB)

..... 2.0 ± 0.3 V

General / 総合

Power Supply / 電源電圧

U, C models AC 120 V, 60 Hz
 R, L models AC 110/120/220/230-240 V, 50/60 Hz
 T model AC 220 V, 50 Hz
 K model AC 220 V, 60 Hz
 A model AC 240 V, 50 Hz
 B, G models AC 230 V, 50 Hz
 J model AC 100 V, 50/60 Hz

Power Consumption / 消費電力

U, C, R, T, K, A, B, G, L models 30 W
 J model 25 W

Off-state Power Consumption / パワー-OFF時消費電力

..... 0 W

Dimensions (W x H x D) / 寸法(幅×高さ×奥行き)

..... 435 x 137 x 440 mm (17-1/8" x 5-3/8" x 17-5/16")

Weight / 質量

..... 15 kg (33 lbs. 1 oz.)

Finish / 仕上げ

Black color U, C, R, T, K, A, B, G, L, J models
 Silver color U, C, R, T, K, A, B, G, L, J models

Accessories / 付属品

Remote control x 1, Battery (R6, AA, UM-3) x 2, Audio pin cable (1.5 m) x 1, Power cable (2 m) x 1

* Specifications are subject to change without notice due to product improvements.

※ 参考仕様および外観は予告なく変更されることがあります。

U U.S.A. model	A Australian model
C Canadian model	B British model
R General model	G European model
T Chinese model	L Singapore model
K Korean model	J Japanese model

• DIMENSIONS / 寸法図

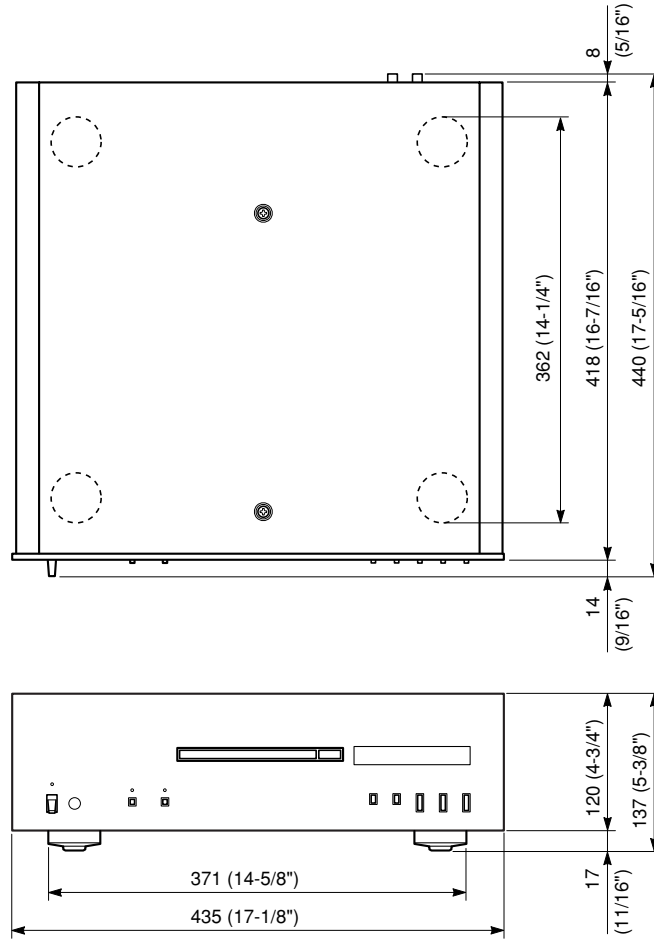

Unit: mm (inch)
 単位：mm(インチ)

■ INTERNAL VIEW

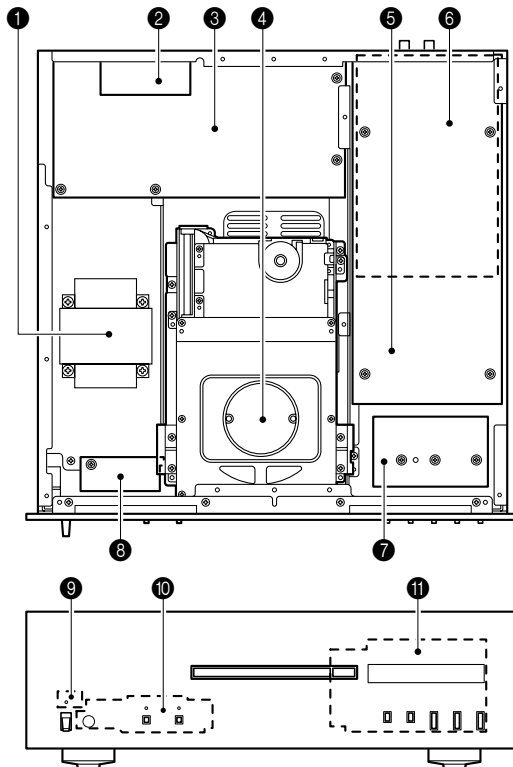

- ① POWER TRANSFORMER
- ② POWER (2) P.C.B. (R, L models)
- ③ POWER (1) P.C.B.
- ④ LOADER UNIT
- ⑤ AUDIO P.C.B.
- ⑥ DIGITAL (1) P.C.B.
- ⑦ DIGITAL (5) P.C.B.
- ⑧ POWER (3) P.C.B.
- ⑨ DIGITAL (4) P.C.B.
- ⑩ DIGITAL (3) P.C.B.
- ⑪ DIGITAL (2) P.C.B.

DISASSEMBLY PROCEDURES / 分解手順

(Remove parts in the order as numbered.)

Disconnect the power cable from the AC outlet.

1. Removal of Panel Side L/R

- a. Remove 2 screws (①), coned disc spring L and washer side. (Fig. 1)
- b. Lift the panel side L a little, release hooks at 3 locations and then remove the panel side L. (Fig. 1)
- c. Remove 2 screws (②) and then remove 2 washers. (Fig. 1)
- d. Lift the panel side R a little, release hooks at 3 locations and remove the panel side R. (Fig. 1)

2. Removal of Top Cover

- a. Remove 7 (U, C models) / 5 (R, T, K, A, B, G, L models) screws (③), 2 screws (④) and 2 screws (⑤). (Fig. 1)
- b. Remove the top cover. (Fig. 1)

(番号順に部品を取り外してください。)

AC電源コンセントから、電源コードを抜いてください。

1. パネルサイド L/Rの外し方

- a. ①のネジ2本、サラバネL、ワッシャーサイドを外します。(Fig. 1)
- b. パネルサイドLを少し持ち上げ、3ヶ所のフックを外し、パネルサイドLを取り外します。(Fig. 1)
- c. ②のネジ2本を外し、ワッシャーサイド2個を外します。(Fig. 1)
- d. パネルサイドRを少し持ち上げ、3ヶ所のフックを外し、パネルサイドRを取り外します。(Fig. 1)

2. トップカバーの外し方

- a. ③ネジ5本、④のネジ2本、⑤のネジ2本を外します。(Fig. 1)
- b. トップカバーを取り外します。(Fig. 1)

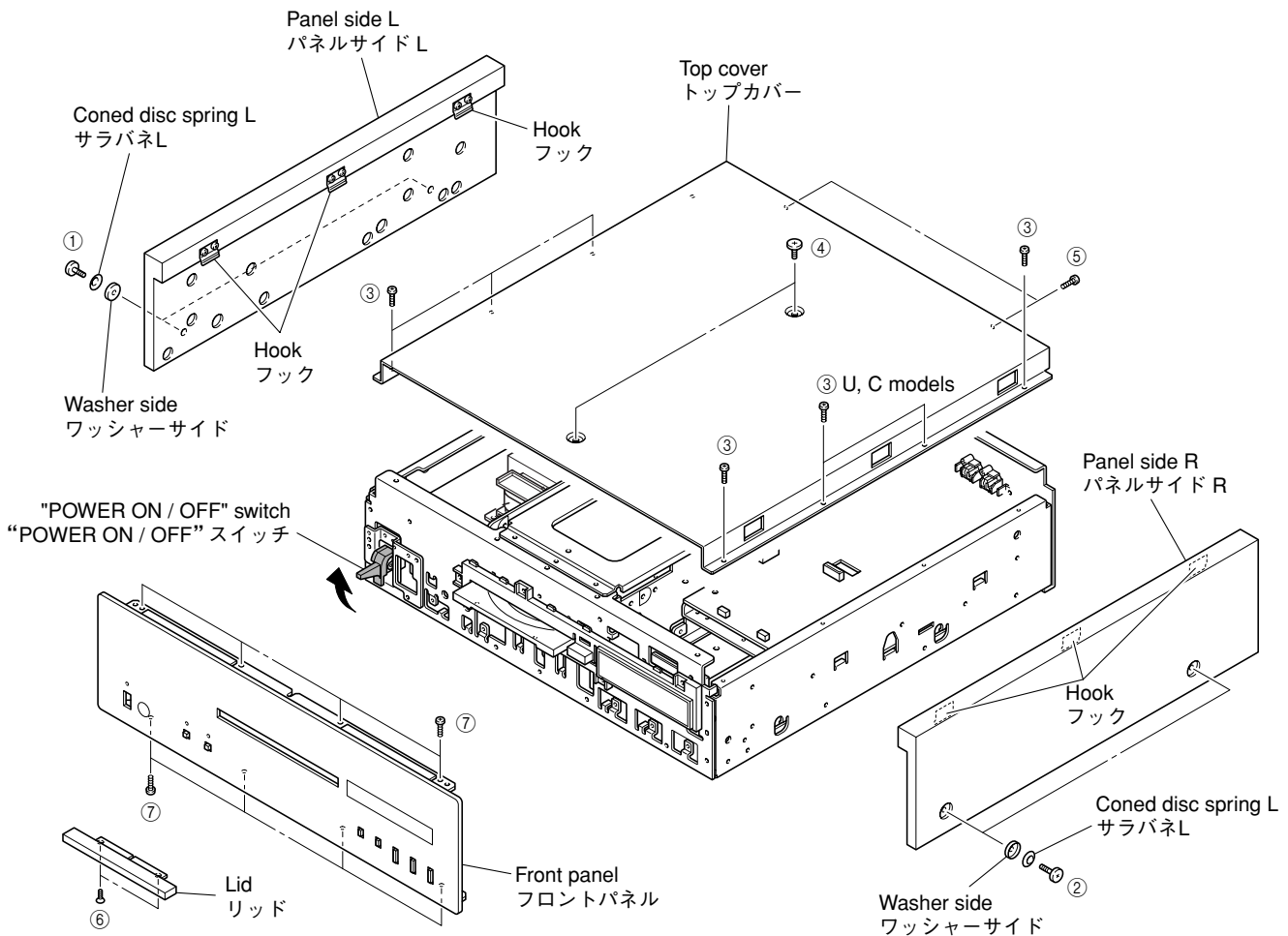

Fig. 1

3. Removal of Front Panel

- Using a flatblade screwdriver, move the slider at the bottom in the direction of the arrow shown below. (Fig. 2)
 - * **Tray lock will be released but will not come out.**
- Push out the tray by pushing its rear. (Fig. 3)
- Using a phillips screwdriver, remove 2 screws (⑥) and then remove the lid. (Fig. 1)
- Close the tray by pushing its front.
- Remove 8 screws (⑦). (Fig. 1)
- Set the "POWER ON/OFF" switch to the ON position.
- Remove the front panel forward gradually, using care not to cause any damage to the "POWER ON/OFF" switch. (Fig. 1)

3. フロントパネルの外し方

- マイナスドライバーで底面のスライダーを下図の矢印の方向に動かします。(Fig. 2)
 - ※ このとき、トレイは押し出されません。
- トレイの後方を押し、トレイを押し出します。(Fig. 3)
- プラスドライバーで⑥のネジ2本を外し、リッドを取り外します。(Fig. 1)
- トレイの前方を押し、トレイを閉じます。
- ⑦のネジ8本を外します。(Fig. 1)
- "POWER ON/OFF"スイッチをONにします。
- "POWER ON/OFF"スイッチに傷がつかないようにフロントパネルを前方へゆっくり取り外します。(Fig. 1)

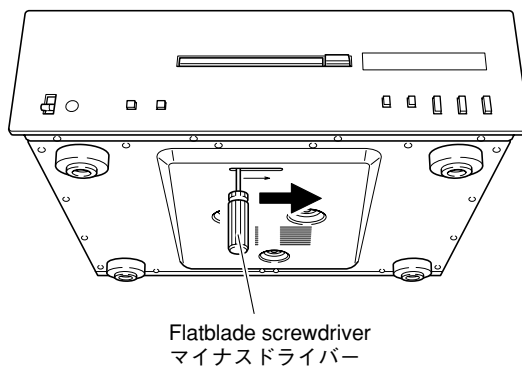

Fig. 2

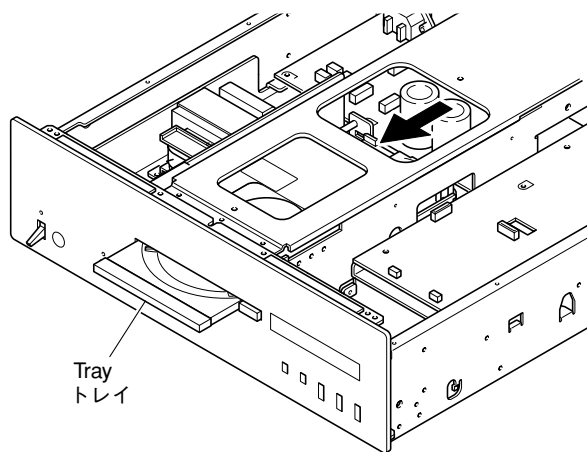

Fig. 3

4. Removal of Front Frame ass'y

- a. Remove 4 screws (⑧), 2 screws (⑨) (B, G models) and then remove the frame top. (Fig. 4)
- b. Remove 9 screws (⑩). (Fig. 4)
- c. Remove CB601 and CB902. (Fig. 4)
- d. Remove the front frame ass'y. (Fig. 4)

5. Removal of AUDIO P.C.B.

- a. Remove 6 screws (⑪). (Fig. 4)
- b. Remove 4 screws (⑫). (Fig. 5)
- c. Remove CB1-2 and CB5-6. (Fig. 4)
- * **When installing CB5 and CB6, be sure to connect the Blue/Black color cable to CB5 and the Red/Black cable to CB6. Both connectors have same shape.**
- d. Lift the front of AUDIO P.C.B. and then remove it. (Fig. 4)

4. フロントフレームASSYの外し方

- a. ⑧のネジ4本、⑨のネジ2本を外し、フレームトップを取り外します。(Fig. 4)
- b. ⑩のネジ9本を外します。(Fig. 4)
- c. CB601、CB902を外します。(Fig. 4)
- d. フロントフレームASSYを取り外します。(Fig. 4)

5. AUDIO P.C.B.の外し方

- a. ⑪のネジ6本を外します。(Fig. 4)
- b. ⑫のネジ4本を外します。(Fig. 5)
- c. CB1-2、CB5-6を外します。(Fig. 4)
- ※ CB5、CB6は同じ形状のため、取り付ける場合には必ず、CB5側へBlue/Black色のケーブル、CB6側へRed/Black色のケーブルを取り付けてください。
- d. AUDIO P.C.B.の前方を持ち上げ、取り外します。(Fig. 4)

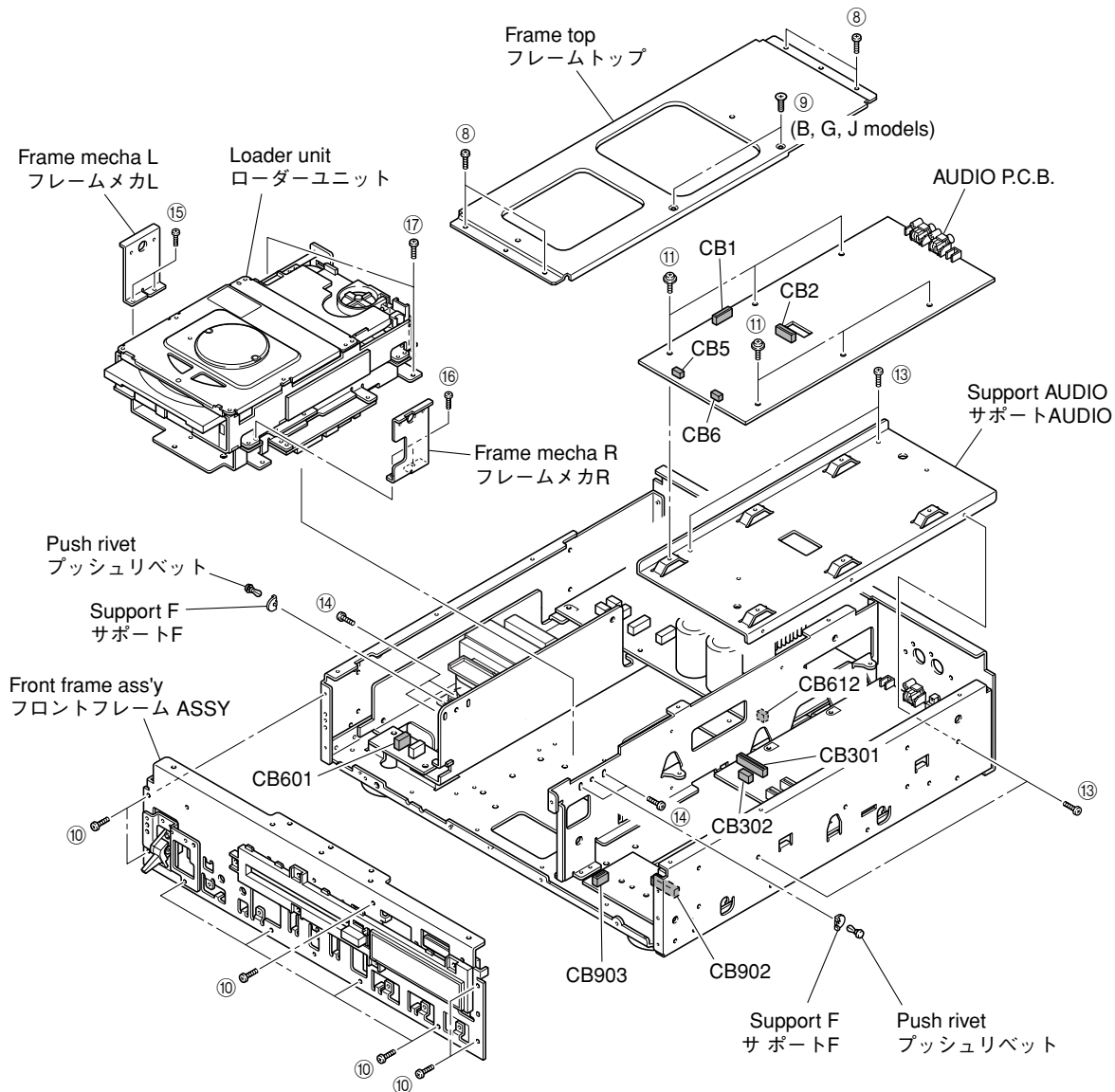

Fig. 4

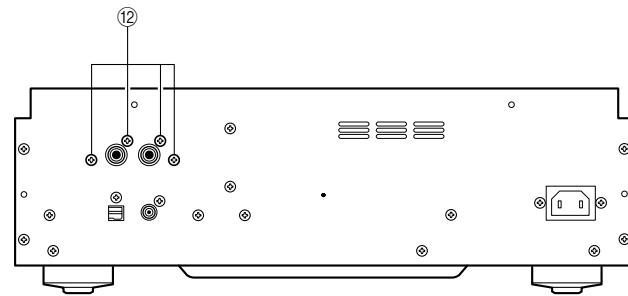

Fig. 5

When checking the AUDIO P.C.B.:

- Put the rubber sheet and cloth over this unit. Then place the P.C.B.s upside down on the cloth and check it. (Fig. 6)
- Reconnect all cables (connectors) that have been disconnected. Use to use the extension cable before connection the following connectors.
AUDIO P.C.B. CB2-DIGITAL P.C.B. CB303
12P, 450mm P=1.25 (MF112450)
- When connecting the flexible flat cable, be careful with polarity.
- In this unit, the ground of P.C.B.s shown below is connected to the rear panel and chassis. When these P.C.B.s are removed from the rear panel, connect the ground point to the rear panel or chassis, using a ground lead wire or the like. (Fig. 6)

AUDIO P.C.B.をチェックをする場合には:

- 本機の上にゴムシートと布を敷き、その上にP.C.B.を裏返しに置いてチェックします。(Fig. 6)
- 外したケーブル(コネクタ)をすべて接続します。ただし次の区間は、サービス用延長ケーブルを使用してください。
AUDIO P.C.B.: CB2-DIGITAL P.C.B.: CB303
12P, 450mm P=1.25 (MF112450)
- フラットケーブルを接続する際、極性に注意してください。
- 本機ではP.C.B.のアースがリアパネルおよびシャーシに接続されています。これらのP.C.B.をリアパネルより取り外した場合は、アース線等でアースポイントをリアパネルまたはシャーシに接続してください。(Fig. 6)

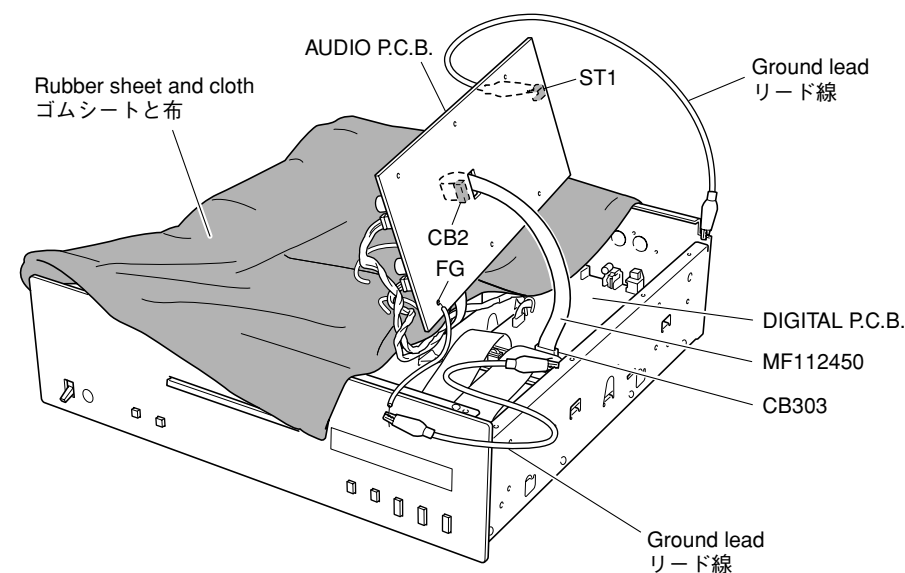

Fig. 6

6. Removal of Loader Unit

- Remove 4 screws (13) and then remove the support audio. (Fig. 4)
- Remove CB301-302, CB612 and CB903. (Fig. 4)
- Remove 4 screws (14). (Fig. 4)
- Remove 2 push rivets and then remove support F on both sides of the loader unit. (Fig. 4)
- Remove 2 screws (15) and then the frame mecha L. (Fig. 4)
- Remove 2 screws (16) and then remove the frame mecha R. (Fig. 4)
- Remove 2 screws (17) and then remove the loader unit. (Fig. 4)

● When installing the Loader Unit:

When installing the loader unit, adjust the clearance between the front panel and lid so that it becomes equal at the top, bottom, right and left.

- Loosen 2 screws (18) and 2 screws (19). (Fig. 7)
- Position the support F on both sides with its flat portion facing upward. (Fig. 7)
- Viewing from the front, confirm the lid position. (Fig. 7)
- Tighten the screws on the side with higher lid inclination (screws (19) in the case shown below). (Fig. 7)
- Turn the support F on the side with lower lid inclination clockwise gradually until the lid is positioned horizontally. (Fig. 7)
- With the lid adjusted at the horizontal position, tighten other screws (screws (18) in the case shown below). (Fig. 7) To change the position upward at this time, loosen screws (19) and then turn the support F clockwise gradually.
* Be sure to make adjustment from either side only.
- Repeat opening and closing the tray some times and confirm to make sure that the same clearance between the front panel and lid is obtained at the top, bottom, right and left.

6. ローダーユニットの外し方

- 13のネジ4本を外し、サポートAUDIOを取り外します。(Fig. 4)
- CB301-302、CB612、CB903を外します。(Fig. 4)
- 14のネジ4本を外します。(Fig. 4)
- ブッシュリベット2個を外し、両側のサポートFを取り外します。(Fig. 4)
- 15のネジ2本を外し、フレームメカLを取り外します。(Fig. 4)
- 16のネジ2本を外し、フレームメカRを取り外します。(Fig. 4)
- 17のネジ2本を外し、ローダーユニットを取り外します。(Fig. 4)

● ローダーユニットを取り付ける場合:

ローダーユニットを取り付ける場合には、フロントパネルとリッドの隙間が上下左右同じになるようにローダーユニットの傾きを調整してください。

- 18のネジ2本、19のネジ2本を緩めます。(Fig. 7)
- サポートFの平らな面を上向きにします。(Fig. 7)
- 前面から見て、リッドの位置を確認します。(Fig. 7)
- リッドの傾斜が高い側のネジ(下図の場合、19のネジ)を締めます。(Fig. 7)
- リッドの傾斜が低い側のサポートFを時計回りにゆっくり回し、リッドの傾きが水平な位置になるようにします。(Fig. 7)
- リッドの位置が水平な位置でネジ(下図の場合、18のネジ)を締めます。(Fig. 7)
このとき上方向へ位置を変更する場合には、次に19のネジを緩め、サポートFを時計回りにゆっくり回します。
※ 調整は必ずどちらか一方から行ってください。
- トレイの開閉を数回行い、フロントパネルとリッドの隙間が上下左右同じであることを確認します。

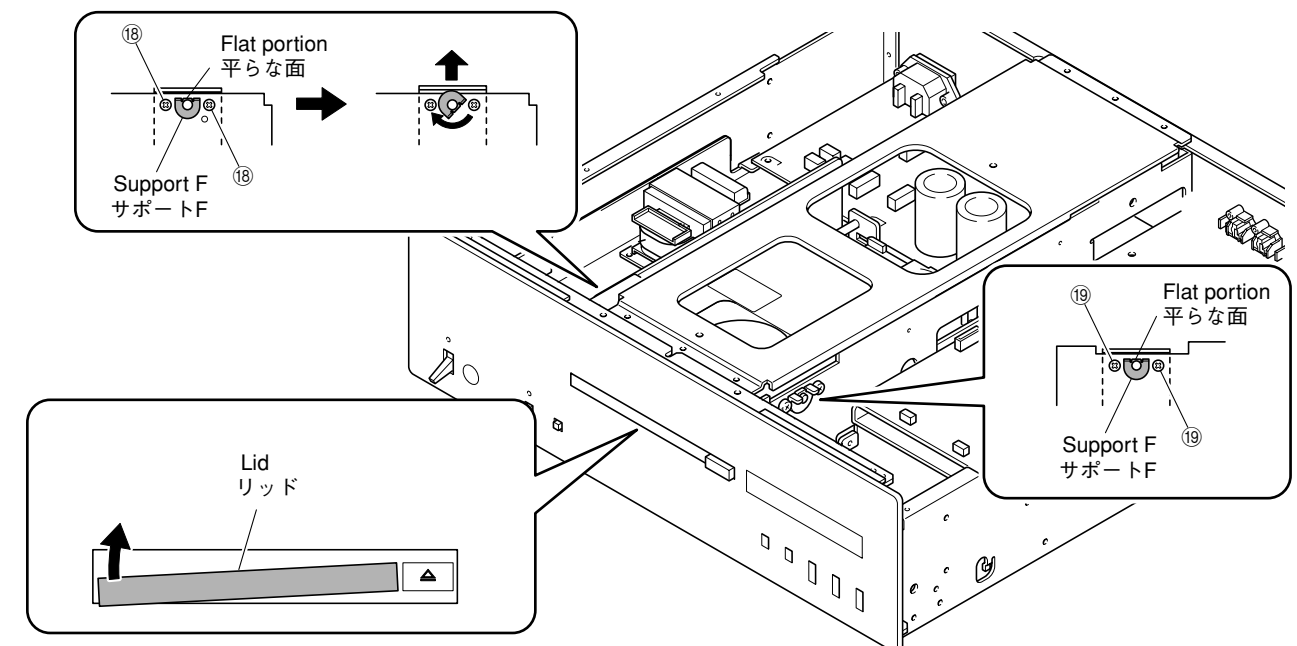

Fig. 7

7. Removal of DIGITAL P.C.B.

- a. Remove 3 screws (20). (Fig. 8)
- b. Remove 4 screws (21). (Fig. 9)
- c. Remove CB610-611 and CB901. (Fig. 8)
- d. Remove the DIGITAL P.C.B.. (Fig. 8)

7. DIGITAL P.C.B.の外し方

- a. 20のネジ3本を外します。(Fig. 8)
- b. 21のネジ4本を外します。(Fig. 9)
- c. CB610-611、CB901を外します。(Fig. 8)
- d. DIGITAL P.C.B.を取り外します。(Fig. 8)

8. Removal of POWER (2) P.C.B. (R and L models)

- a. Remove 2 screws (22). (Fig. 9)
- b. Remove the POWER (2) P.C.B.. (Fig. 8)

8. POWER(1) P.C.B.の外し方

- a. 23のネジ4本を外します。(Fig. 8)
- b. 24のネジ2本、25のネジ2本を外します。(Fig. 9)
- c. CB603、CB606-607、CB615を外します。(Fig. 8)
- d. POWER(1) P.C.B.を取り外します。(Fig. 8)

9. Removal of POWER (1) P.C.B.

- a. Remove 4 screws (23). (Fig. 8)
- b. Remove 2 screws (24) and 2 screws (25). (Fig. 9)
- c. Remove CB603, CB606-607, CB615 and CB604 (R, L models). (Fig. 8)
- d. Remove the POWER (1) P.C.B.. (Fig. 8)

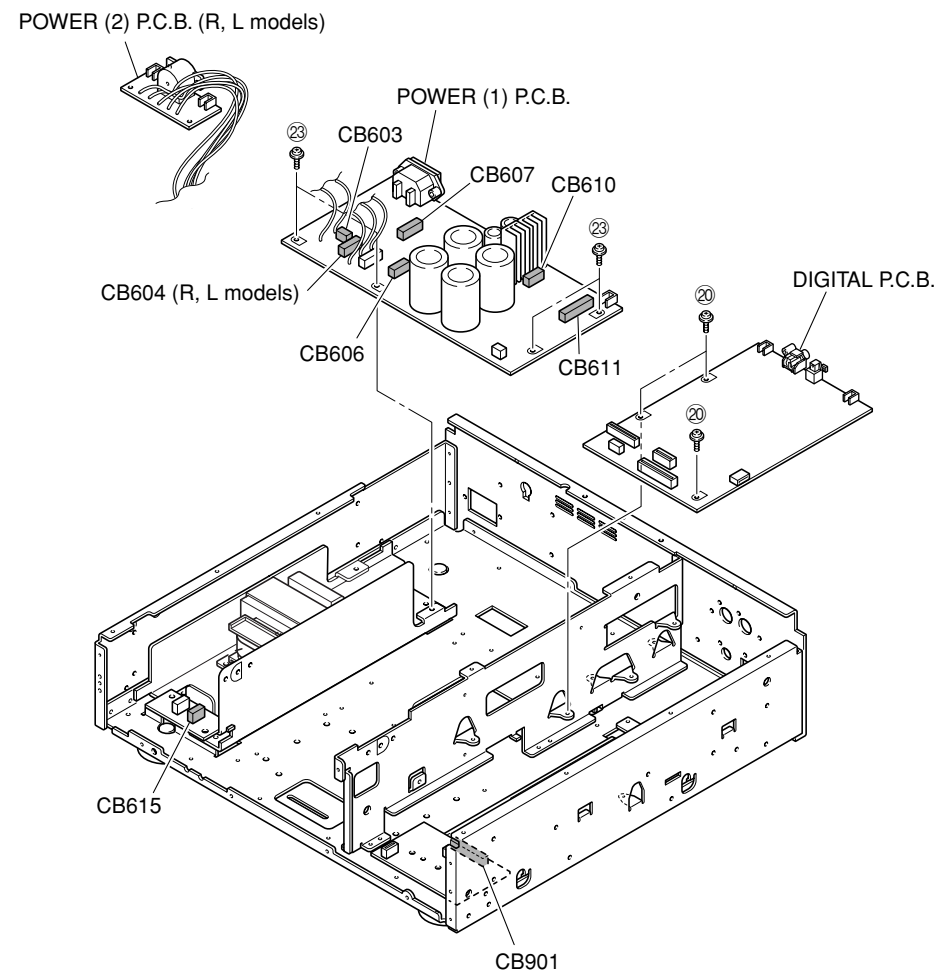

Fig. 8

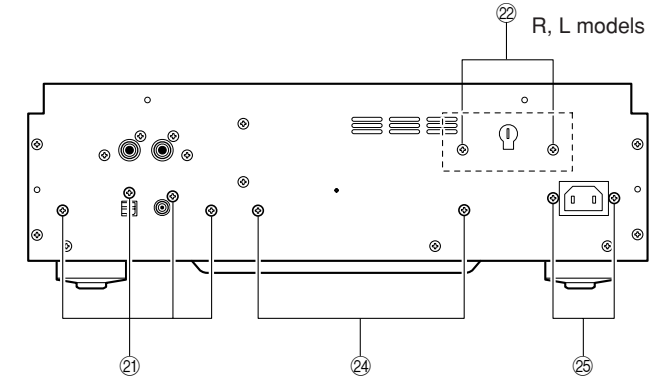

Fig. 9

● **Disassembly of Loader Unit**

1. Removal of Module Board

- a. Remove CN102 and CN103. (Fig. 10)
- b. Unlock CN101 and then disconnect the flexible flat cable, and ground the terminal face of the flexible flat cable with a clip or the like. (Fig. 10)
- c. Remove 5 screws (26). (Fig. 10)
- d. Remove the module board. (Fig. 10)

● **ローダーユニットの分解手順**

1. モジュール基板の外し方

- a. CN102-103を外します。(Fig. 10)
- b. CN101のロックを解除してカード電線を外します。次に外したカード電線のクリップ等で端子面をアースします。(Fig. 10)
- c. 26のネジ5本を外します。(Fig. 10)
- d. モジュール基板を取り外します。(Fig. 10)

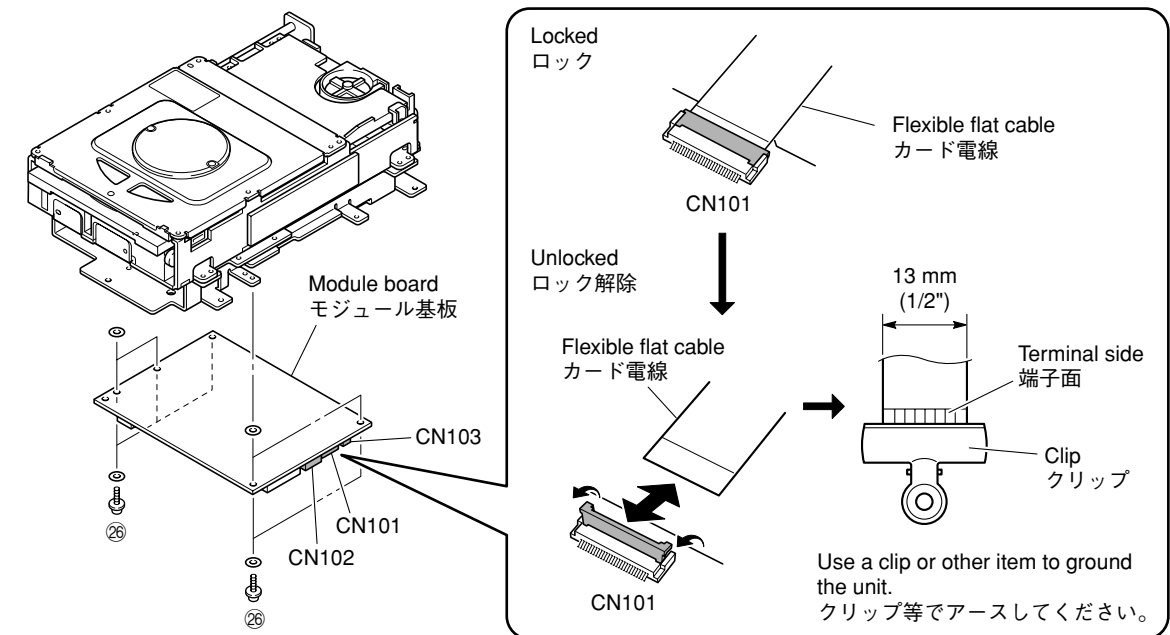

Fig. 10

2. Removal of DVD Traverse Mechanism and Stepping Motor.

* When installing a new DVD traverse mechanism, remove the solder from the shorted point of pick up unit using an electrostatic shielding soldering iron.

- Remove 6 screws (27) and then remove the clamp ass'y. (Fig. 11)
- Push out the tray by pushing its rear. (Fig. 11)
- Remove 2 screws (28). (Fig. 11)
- Remove the DVD traverse mechanism together with the holder PU/SA-CD. (Fig. 11)
- Remove 4 screws (29) and then remove the DVD traverse mechanism. (Fig. 11)
- Remove 2 screws (30) and then remove the stepping motor. (Fig. 11)

2. DVDトラバースメカおよびステッピングモーターの外し方

※ 新しいDVDトラバースメカに交換する場合、ピックアップユニットのショート箇所のハンダを静電気対策ハンダごてで取り除いてください。

- 27のネジ6本を外し、クランプASSYを取り外します。(Fig. 11)
- トレイの後方を押し、トレイを押し出します。(Fig. 11)
- 28のネジ2本を外します。(Fig. 11)
- DVDトラバースメカをホルダーPU/SA-CDと一緒に取り外します。(Fig. 11)
- 29のネジ4本を外し、DVDトラバースメカを取り外します。(Fig. 11)
- 30のネジ2本を外し、ステッピングモーターを取り外します。(Fig. 11)

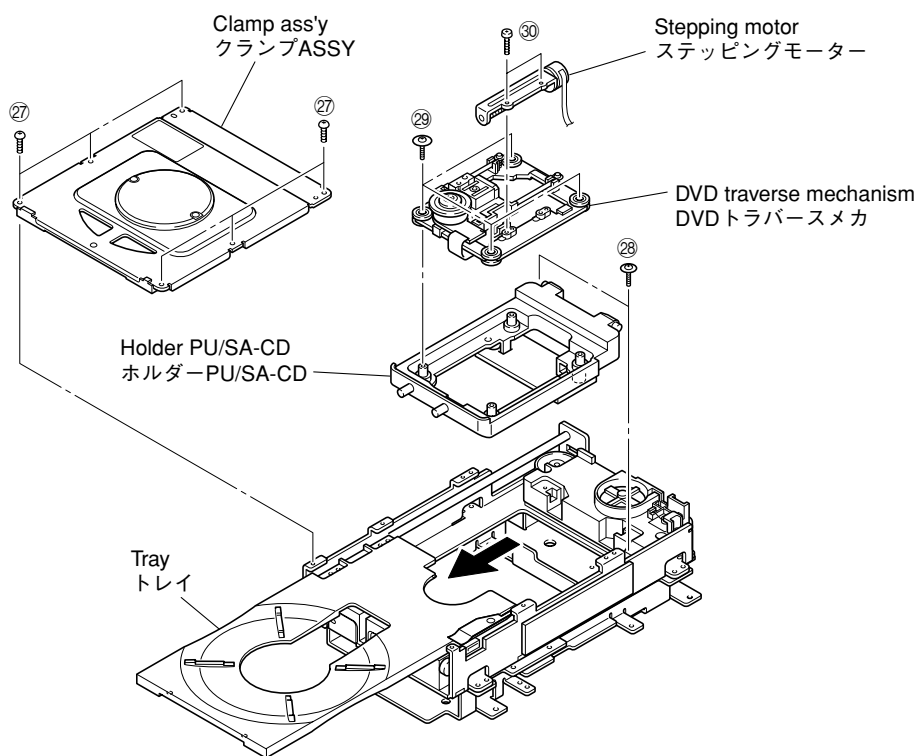

Fig. 11

- **When installing a new Stepping Motor:**
Before installing a new stepping motor, apply grease to its screw.

Recommended grease:

PN-397 (Part No.: AAX89650)

- Apply grease to the screw at 3 points as shown below. (Fig. 12)
 - * Amount of grease to be applied:
3mg ± 1mg at 3 points
- After applying grease, spread it evenly between A and B of the screw of the stepping motor. (Fig. 13)
 - * **While spreading grease evenly, use full care not to cause damage to the screw.**
 - * **If waste thread, dust, etc. is attached, remove it.**
- Apply grease to the DVD traverse mechanism as shown below. (Fig. 14)
 - * Amount of grease to be applied:
2 mg ± 1mg at 1 point

- **Operation check after installing a new stepping motor**

After installing all parts, turn on the power and check for proper operation.

- Load CD, repeat the search function between the first number and the last one some times so that the grease is settled.
- Perform random playback and check for proper operation.

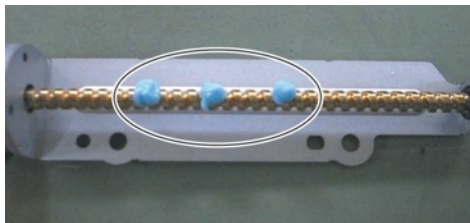

Fig. 12

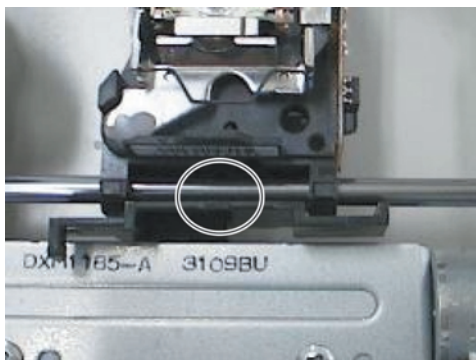

Fig. 14

- **新しいステッピングモーターを取り付ける場合:**
新しいステッピングモーターを取り付ける場合には、新しいステッピングモーターのスクリー部分にグリスを塗布します。

推奨グリス：PN-397 (部品番号：AAX89650)

- スクリー部の下図3ヶ所にグリスを塗布します。(Fig. 12)
 - ※ 塗布量：3 mg ± 1 mg × 3ヶ所
- グリスを塗布した後、ステッピングモーターのスクリー部A-B間にグリスを均一に伸ばします。(Fig. 13)
 - ※ グリスを均一に伸ばす場合、スクリー部にキズをつけないよう十分注意してください。
 - ※ 糸くずやほこり等が付着した場合、糸くずやほこり等を取り除いてください。
- DVDトラバースメカの下図にグリスを塗布します。(Fig. 14)
 - ※ 塗布量：2 mg ± 1 mg × 1ヶ所

- **新しいステッピングモーター取り付け後の動作確認**
すべての部品を取り付けた後、電源を入れて動作確認を行います。

- CDを入れて、1曲目と最終曲間のサーチを数回繰り返し、グリスを馴染ませます。
- ランダム再生を行い、問題なく再生できるか確認します。



Fig. 13

■ TEST MODE / テストモード

● Starting Test Mode

To activate the TEST mode, set the "POWER ON/OFF" switch to the ON position while pressing the keys of this unit as shown below at the same time.

● テストモード起動

本機の下図に示すキーを同時に押しながら"POWER ON/OFF"スイッチをONにすると、テストモードが起動します。

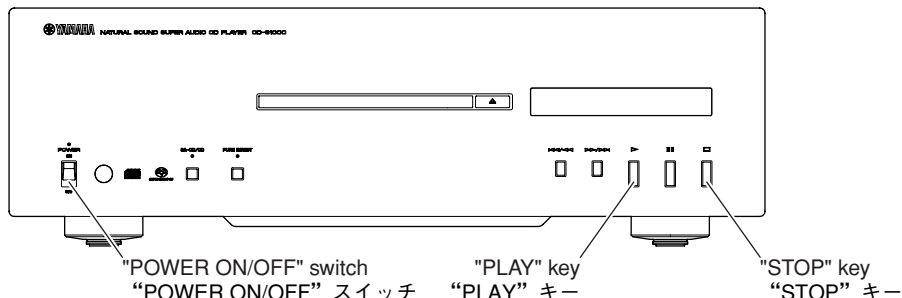

When the power is ON
電源オン時

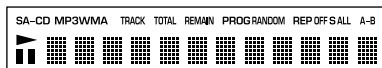

Starting TEST mode
テストモード起動



Release the "PLAY" and "STOP" keys.
"PLAY" キーおよび "STOP" キーを放す

Firmware version of microprocessor is displayed. /
マイコンのファームウェアバージョン表示

● Operating Test Mode

Press the "DISPLAY" key on the remote control, and the display changes in the order as shown below.

● テストモードの操作方法

リモコンの"DISPLAY"キーを押すと、下図の順で表示が切り替わります。

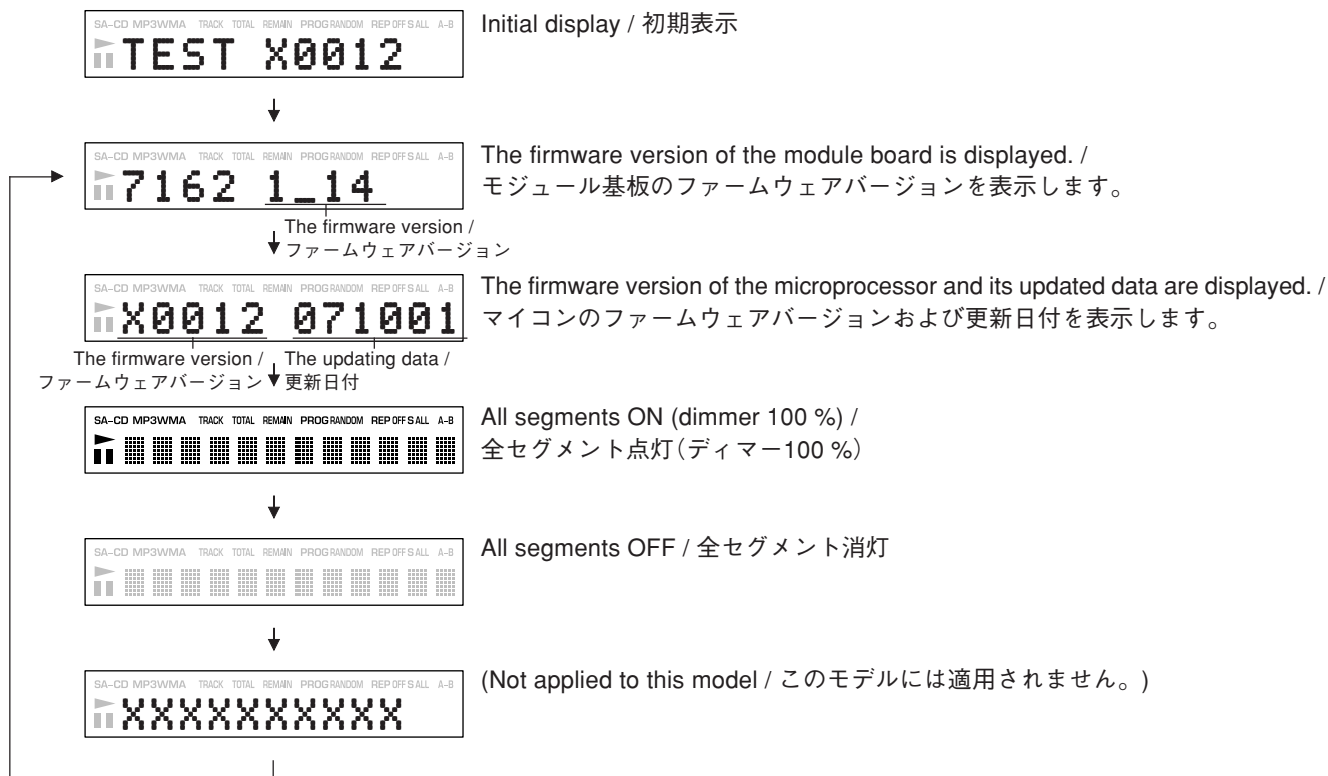

■ UPDATING FIRMWARE / ファームウェアの書き込み

Writing to the microprocessor

After replacing the following parts update the latest firmware according to the following procedure.

DIGITAL P.C.B.
Microprocessor (IC302) of DIGITAL P.C.B.

● Required tools

- **Program downloader programs**
..... FlashSta.exe
 - **Firmware**
..... CDS1000xx.S
..... CDS1000xx.id
 - **RS232C cross cable “D-sub 9 pin female”**
(Specifications)
- | | | |
|--------------|---|--------------|
| Pin No.2 RxD | ✕ | Pin No.2 RxD |
| Pin No.3 TxD | ✕ | Pin No.3 TxD |
| Pin No.5 GND | — | Pin No.5 GND |
| Pin No.7 RTS | ✕ | Pin No.7 RTS |
| Pin No.8 CTS | ✕ | Pin No.8 CTS |
- **RS232C conversion jig (Part No.: AAX88050)**

● Preparation and precautions before starting the operation

- Download firmware downloader program and firmware from the specified source to the same folder of the PC.
- Prepare the above specified RS232C cross cable.
- While writing, keep the other application software on the PC closed.
It is also recommended to keep the software on the task tray closed as well.

マイコンへの書き込み

下記の部品を交換した場合、下記の手順により最新のファームウェアの書き込みを行ってください。

DIGITAL P.C.B.
DIGITAL P.C.B.のマイコン(IC302)

● 必要なツール

- プログラム書き込み用プログラム
..... FlashSta.exe
 - ファームウェア
..... CDS1000xx.S
..... CDS1000xx.id
 - **RS232Cクロスケーブル“D-sub 9pinメス”**
(仕様)
- | | | |
|--------------|---|--------------|
| Pin No.2 RxD | ✕ | Pin No.2 RxD |
| Pin No.3 TxD | ✕ | Pin No.3 TxD |
| Pin No.5 GND | — | Pin No.5 GND |
| Pin No.7 RTS | ✕ | Pin No.7 RTS |
| Pin No.8 CTS | ✕ | Pin No.8 CTS |
- **RS232C 変換治具 (部品番号：AAX88050)**

● 操作前の準備と注意

- PCへ指定のダウンロード先からファームウェア書き込み用プログラムおよび、ファームウェアを同じフォルダにダウンロードしてください。
- RS232Cクロスケーブルは必ず上記仕様のもを用意してください。
- 書き込み時は、PC上の他のアプリケーションソフトは閉じてください。
さらに、タスクトレイ上にあるソフトも閉じておくことを推奨します。

● Operation Procedures

1. Turn off the power of this unit and disconnect the power cable from the AC outlet.
2. Remove 2 screws (①). (Fig. 1)
3. Lift the panel side R a little, release hooks at 3 locations and then remove the panel side R. (Fig. 1)
4. Connect the writing port of this unit to the serial port (RS232C) of the PC with RS232C cross cable, RS232C conversion jig and flexible flat cable as shown below. (Fig. 1)

● 操作手順

1. 本機の電源を切り、電源コードをACコンセントから抜きます。
2. ①のネジ2本を外します。(Fig. 1)
3. パネルサイドRを少し持ち上げ、フック3ヶ所を外し、パネルサイドRを取り外します。(Fig. 1)
4. 本機の書き込み用ポートとPCのシリアルポート(RS232C)を下記のように接続します。(Fig. 1)

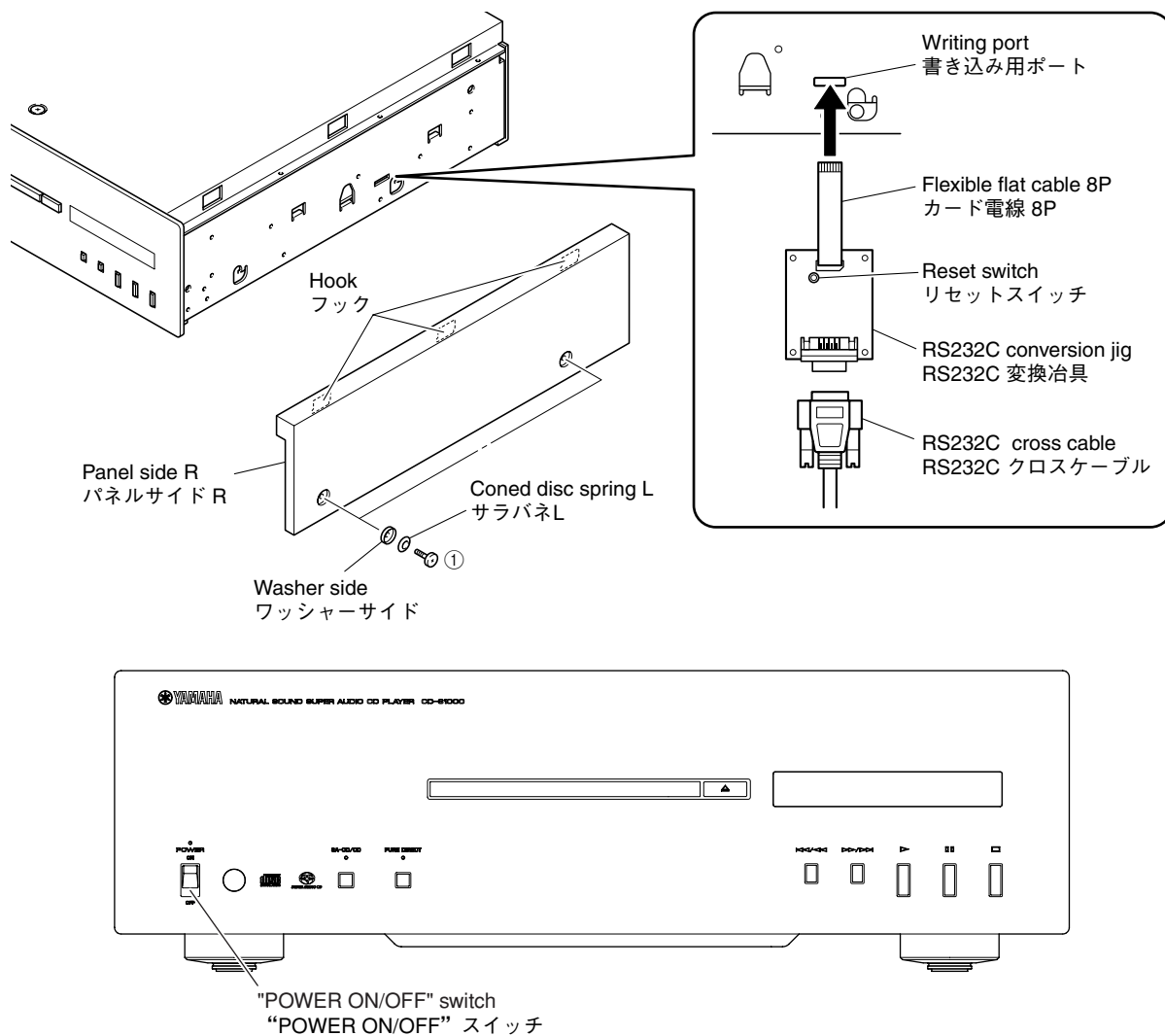

Fig. 1

5. Connect the power cable of this unit to the AC outlet. (Fig. 1)
6. While pressing the reset switch of RS232C conversion jig, set the "POWER ON/OFF" switch of this unit to the ON position. (Fig. 1)

5. 本機の電源コードをACコンセントに接続します。(Fig. 1)
6. RS232C変換治具のリセットスイッチを押しながら、本機の"POWER ON/OFF"スイッチをONにします。(Fig. 1)

7. Start up FlashSta.exe, the screen will appear as shown below. (Fig. 2)

7. FlashSta.exeを立ち上げます。すると下記の画面が表示されます。(Fig. 2)

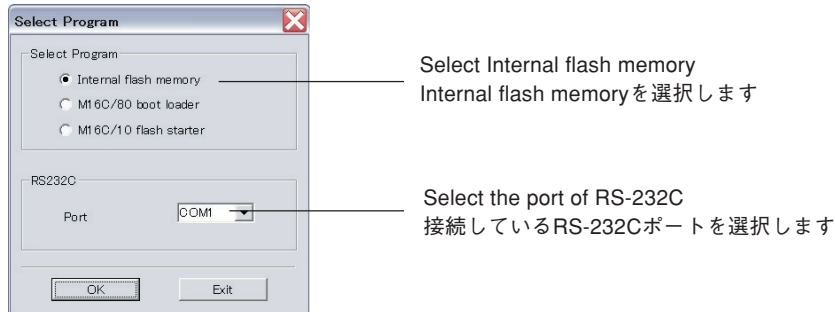

Select Internal flash memory
Internal flash memoryを選択します

Select the port of RS-232C
接続しているRS-232Cポートを選択します

Fig. 2

8. Select the port and data to be transmitted. (Fig. 2)

8. 送信データ、ポートを選択します。(Fig. 2)

- **Select Program**
Select Internal flash memory
- **RS232C**
Select the port of RS-232C
- * For selection of the port, COM1 to 4 can be used.
As COM5 or higher port cannot be used, select out of COM 1 to 4 of the setting on the PC side.

- **Select Program**
Internal flash memoryを選択します。
- **RS232C**
接続しているRS-232Cポートを選択します。
※ ポートの選択はCOM1~4までが使用できません。
COM5以上は使用できませんので、PC側の設定でCOM1~4を選択してください。

9. Click [Refer...]. And select the firmware name. (Fig. 3)

9. [Refer...]をクリックし、書き込むファームウェアを選択します。(Fig. 3)

* The ID code and MCU type are loaded automatically when the file is selected. (Fig. 3)

※ ID、およびMCU Typeは書き込みファイル選択時、自動的に取り込まれます。(Fig. 3)

Click [OK]. (Fig. 3)

[OK]をクリックします。(Fig. 3)

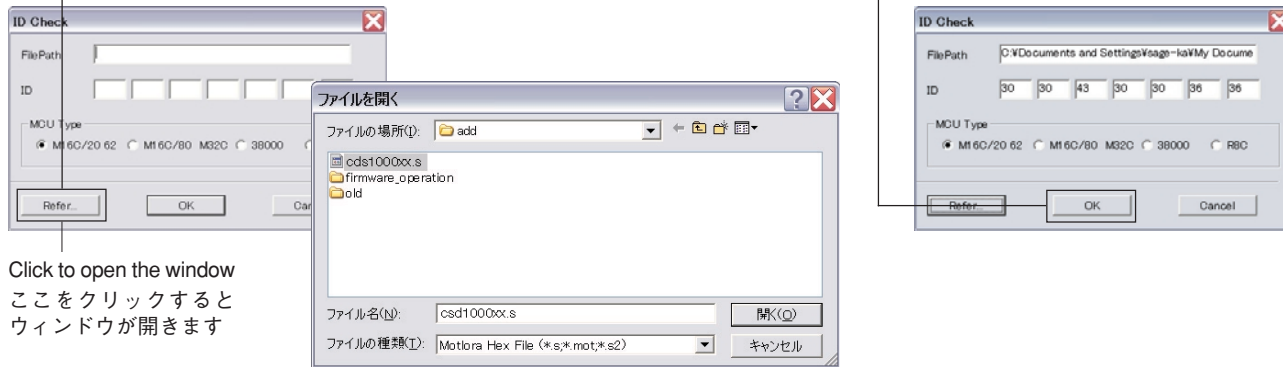

Click to open the window
ここをクリックすると
ウィンドウが開きます

Fig. 3

10. Click [E.P.R.], the screen appears as shown below. (Fig. 4)

10. [E.P.R.]をクリックすると、下記の画面が表示されます。(Fig. 4)

Click [OK] to start writing. (Fig. 4)

[OK]をクリックし、書き込みを開始します。(Fig. 4)

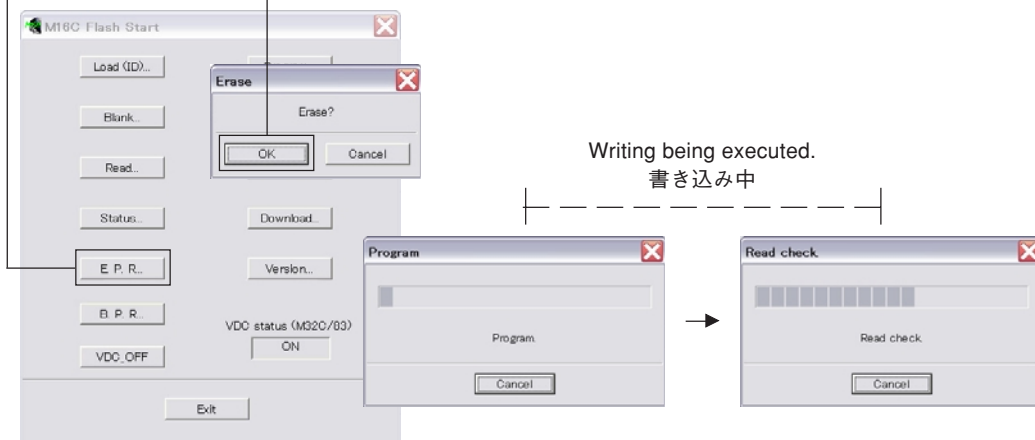

Fig. 4

11. When the program transmission is completed, the screen appears as shown below. (Fig. 5)
Click [OK] to end the procedure. (Fig. 5)

11. プログラムの送信が終了すると、下記の画面が表示されます。(Fig. 5)
[OK]をクリックして完了します。(Fig. 5)

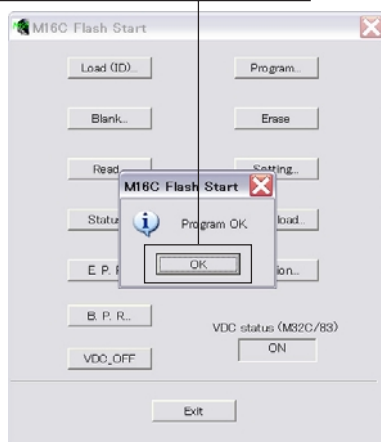

Fig. 5

12. Set the "POWER ON/OFF" switch of this unit to the OFF position.
13. Disconnect the power cable of this unit from the AC outlet.
14. End "FlashSta. exe."
15. Disconnect the RS232C cross cable, RS232C conversion jig and flexible flat cable.

• **Confirmation of firmware version**

Confirm the firmware is updated successfully from the test mode.

For more information, refer to "TEST MODE".

1. Connect the power cable of this unit to the AC outlet.
2. While pressing the "PLAY" and "STOP" keys of this unit, set the "POWER ON/OFF" switch to the ON position. Test mode is activated. (Fig. 6)
3. Press the "DISPLAY" key on the remote control, select the function to display the firmware version of the microprocessor. Check that the displayed firmware version is the same as written firmware version.

12. 本機の"POWER ON/OFF"スイッチをOFFにします。
13. 本機の電源コードをACコンセントから抜きます。
14. "FlashSta.exe"を終了します。
15. RS232Cクロスケーブル、RS232C変換アダプターカード電線を取り外します。

• **ファームウェアバージョンの確認**

テストモードでファームウェアが正しく更新されたことを確認します。

テストモードの詳細は「テストモード」を参照してください。

1. 本機の電源コードをACコンセントに接続します。
2. 本機の"PLAY"キーと"STOP"キーを押しながら、"POWER ON/OFF"スイッチをONにします。(Fig. 6) テストモードが起動します。
3. リモコンの"DISPLAY"キーを押し、マイコンのファームウェアバージョンの表示を選択します。表示されたファームウェアのバージョンが書き込んだファームウェアのバージョンと同じであることを確認します。

Key of this unit / 本体キー

Set the "POWER ON/OFF" switch to the ON position while pressing these keys.
これらのキーを同時に押しながら、
"POWER ON/OFF" スイッチをONにします。

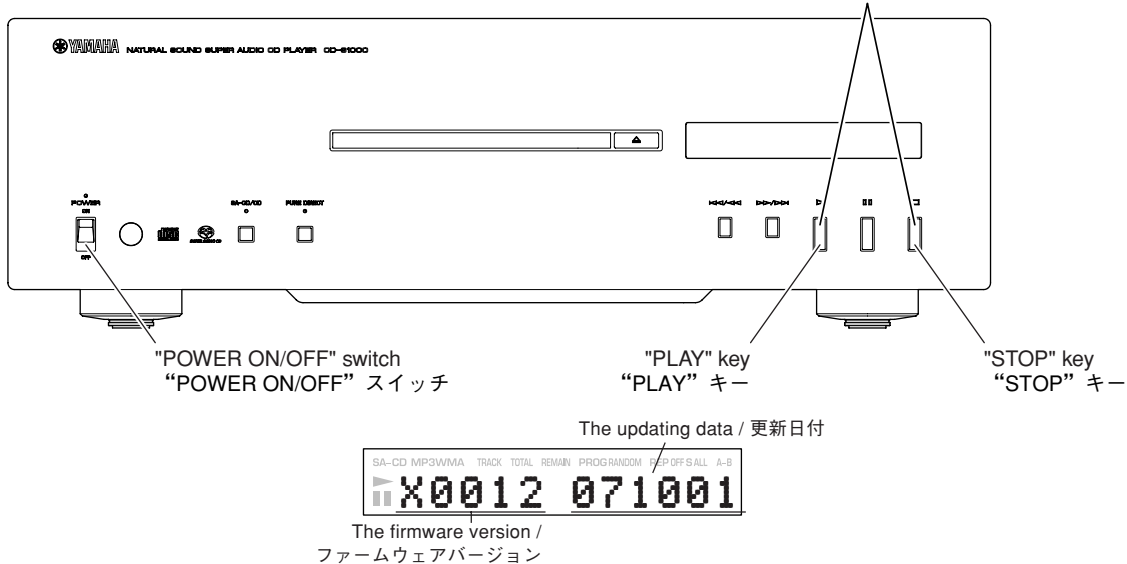

Fig. 6

* When the displayed firmware version is different from written firmware version, follow the steps from 1 to 15 of operation procedures again.

※ 表示されたファームウェアのバージョンが、書き込んだファームウェアのバージョンと異なる場合、操作手順の1から15までをもう一度実施してください。

Writing to the Module Board

After replacing the Module board with the replacement part, be sure to write the latest firmware.

- **Required Tools**

Firmware CD

* To make the firmware CD, download the latest firmware from the specified download source to PC.

Firmware: S5JAxxx6.BIN

- **Operation Procedures**

CAUTION: Do not turn off the power while updating the firmware.

1. Connect the power cable of this unit to the AC outlet.
2. Set the "POWER ON/OFF" switch of this unit to the ON position. (Fig. 7)
3. Press the "OPEN/CLOSE" key of this unit to open the tray. (Fig. 7)

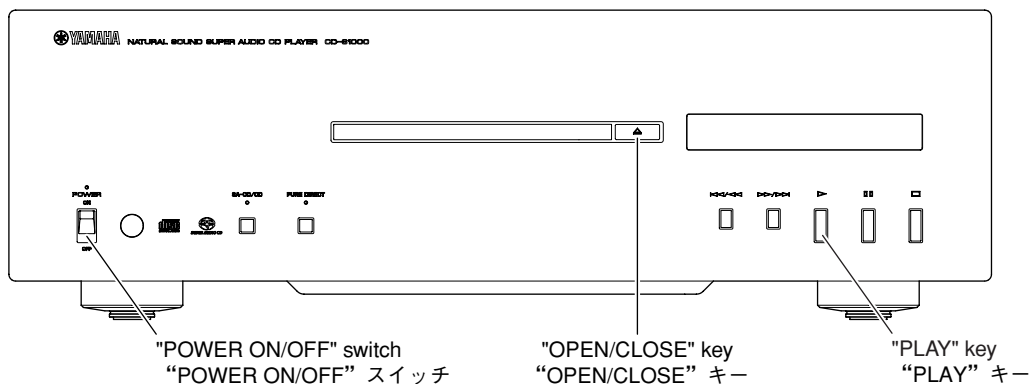

Fig. 7

4. Put the firmware CD on the tray and close the tray. Then "UPGRADE?" is displayed.

4. ファームウェアCDをトレーに載せ、トレーを閉じます。すると、「UPGRADE?」が表示されます。



5. Press the "PLAY" key of this unit, and then writing of the firmware is started and "UPGRADE" flashes.

5. 本機の"PLAY"キーを押し、書き込みを開始します。すると、「UPGRADE」が点滅します。

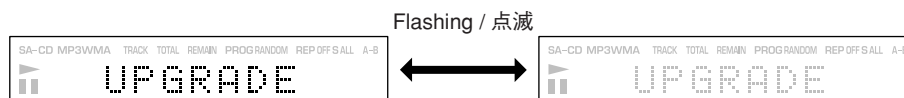

6. After about 5 seconds, the tray opens automatically.
Remove the firmware CD.
* At this time, do not turn off the power as writing of the firmware is going on in this unit.
* Writing takes about 1 minute.
7. When writing is completed, the tray closes automatically.
8. After "NO DISC" is displayed, set the "POWER ON/OFF" switch to the OFF position.

6. 約5秒後、自動でトレイが開きます。
ファームウェアCDを取り出します。
※ このとき、本機はファームウェアの書き込みを継続しています。電源は切らないでください。
※ 書き込み時間は、約1分間ほどかかります。
7. 書き込み終了後、トレイが自動で閉じます。
8. "NO DISC"と表示された後、"POWER ON/OFF"スイッチをOFFにします。

• **Confirmation of firmware version**

Confirm the firmware is updated successfully from the test mode.
For more information, refer to "TEST MODE".

1. Connect the power cable of this unit to the AC outlet.
2. While pressing the "PLAY" and "STOP" keys of this unit, set the "POWER ON/OFF" switch to the ON position. Test mode is activated. (Fig. 8)
3. Press the "DISPLAY" key on the remote control, select the function to display the firmware version of the module board. Check that the displayed firmware version is the same as written firmware version.

• **ファームウェアバージョンの確認**

テストモードでファームウェアが正しく更新されたことを確認します。
テストモードの詳細は「テストモード」を参照してください。

1. 本機の電源コードをACコンセントに接続します。
2. 本機の"PLAY"キーと"STOP"キーを押しながら、"POWER ON/OFF"スイッチをONにします。(Fig. 8)
テストモードが起動します。
3. リモコンの"DISPLAY"キーを押し、モジュール基板のファームウェアバージョンの表示を選択します。
表示されたファームウェアのバージョンが書き込んだファームウェアのバージョンと同じであることを確認します。

Key of this unit / 本体キー

Set the "POWER ON/OFF" switch to the ON position while pressing these keys.
これらのキーを同時に押しながら、"POWER ON/OFF"スイッチをONにします。

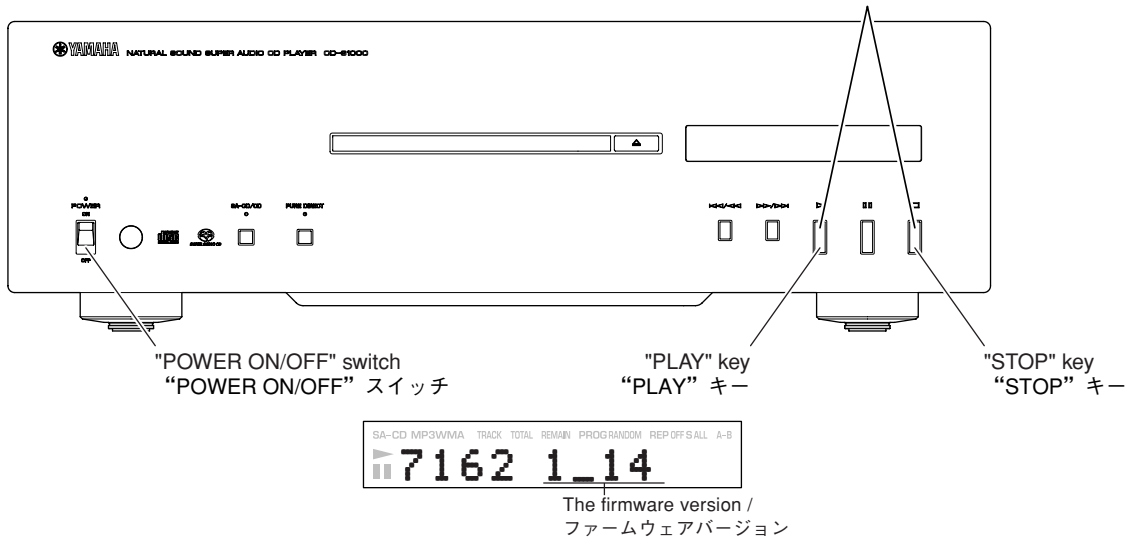

Fig. 8

* When the displayed firmware version is different from written firmware version, follow the steps from 1 to 8 of operation procedures again.

※ 表示されたファームウェアのバージョンが、書き込んだファームウェアのバージョンと異なる場合、操作手順の1から8までをもう一度実施してください。

■ DISPLAY DATA

● V800 : 13-ST-81GINK (DIGITAL (2) P.C.B.)

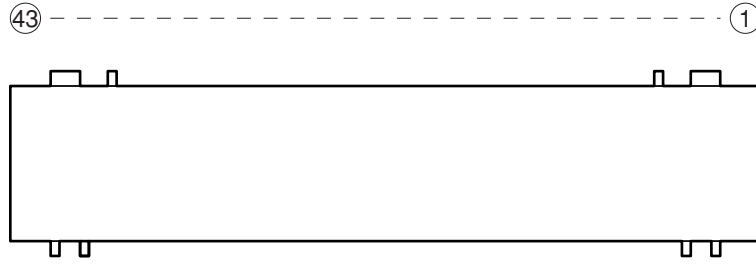

● PIN CONNECTION

Pin No.	19	18	17	16	15	14	13	12	11	10	9	8	7	6	5	4	3	2	1
Connection	NX	NX	NX	NX	NX	NX	NX	NX	NX	NX	NX	NX	NX	NX	13G	Q13G	NP	NP	F1
Pin No.	37	36	35	34	33	32	31	30	29	28	27	26	25	24	23	22	21	20	
Connection	VDD	OSC	RESET	CS	CP	DA	TSA	TSB	NX	NX	NX	NX	NX	NX	NX	NX	NX	NX	
Pin No.	43	42	41	40	39	38													
Connection	F2	NP	NP	LGND	PGND	VH													

Note: 1) F1, F2 Filament 2) NP No pin 3) NX No extended pin 4) DL Datum line 5) LGND Logic GND pin
 6) PGND Power GND pin 7) VH High voltage supply pin 8) VDD Logic voltage supply pin 9) CP Shift register clock
 10) DA Serial data input 11) TSA, B Test pin 12) CS Chip select input pin 13) OSC Pin for self-oscillation
 14) RESET Reset input 16) Q13G Driver output port 17) 13G Grid

● GRID ASSIGNMENT

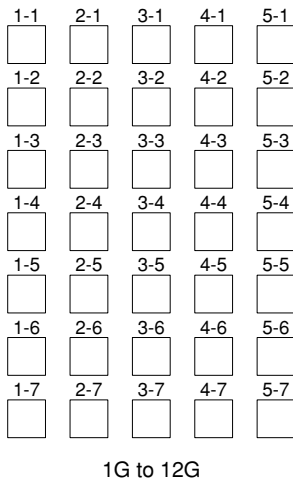
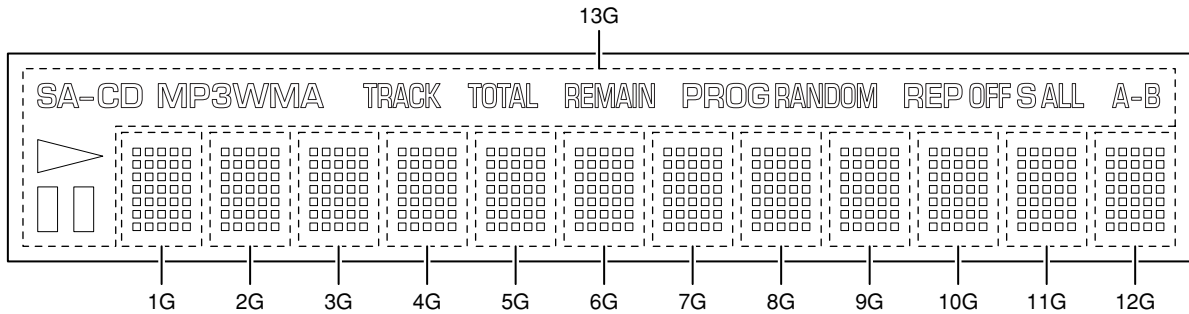

● ANODE CONNECTION

	1G to 12G	13G		1G to 12G	13G		1G to 12G	13G
D0	1-1		D15	1-4	CD	D30	1-7	-
D1	2-1		D16	2-4	SA-	D31	2-7	-
D2	3-1	B	D17	3-4	-	D32	3-7	-
D3	4-1	A-	D18	4-4	-	D33	4-7	-
D4	5-1	ALL	D19	5-4	-	D34	5-7	-
D5	1-2	S	D20	1-5	-			
D6	2-2	OFF	D21	2-5	-			
D7	3-2	REP	D22	3-5	-			
D8	4-2	RANDOM	D23	4-5	-			
D9	5-2	PROG	D24	5-5	-			
D10	1-3	REMAIN	D25	1-6	-			
D11	2-3	TOTAL	D26	2-6	-			
D12	3-3	TRACK	D27	3-6	-			
D13	4-3	WMA	D28	4-6	-			
D14	5-3	MP3	D29	5-6	-			

IC DATA

IC302: M30302FAPFP (DIGITAL (1) P.C.B.)
Single-chip 16-bit microprocessor

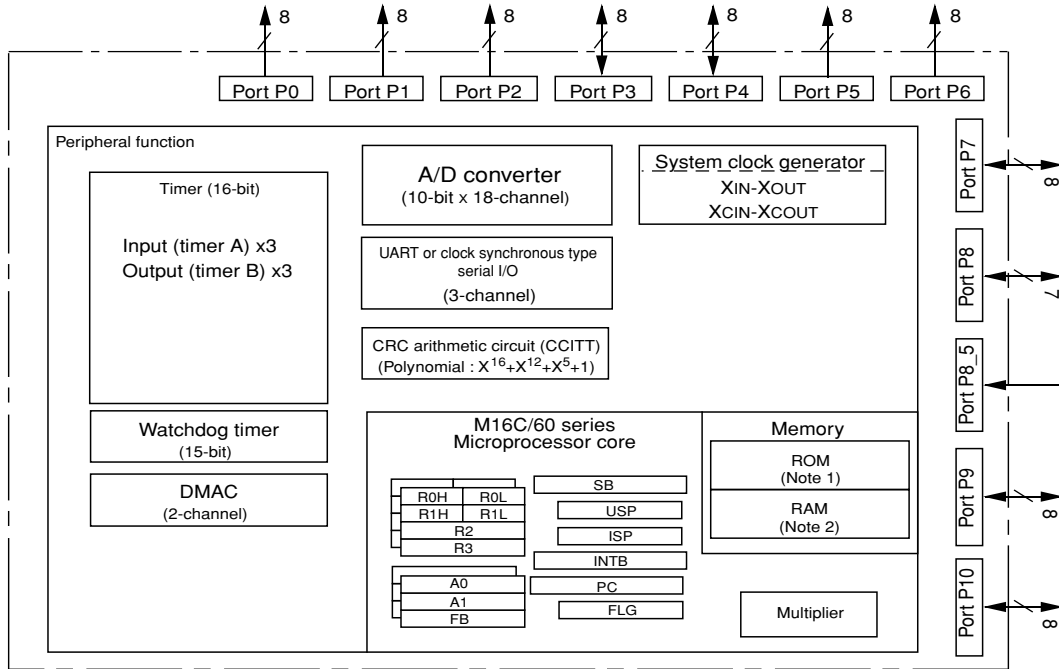

Note 1: ROM contents vary depending on types.
Note 2: RAM contents vary depending on types.

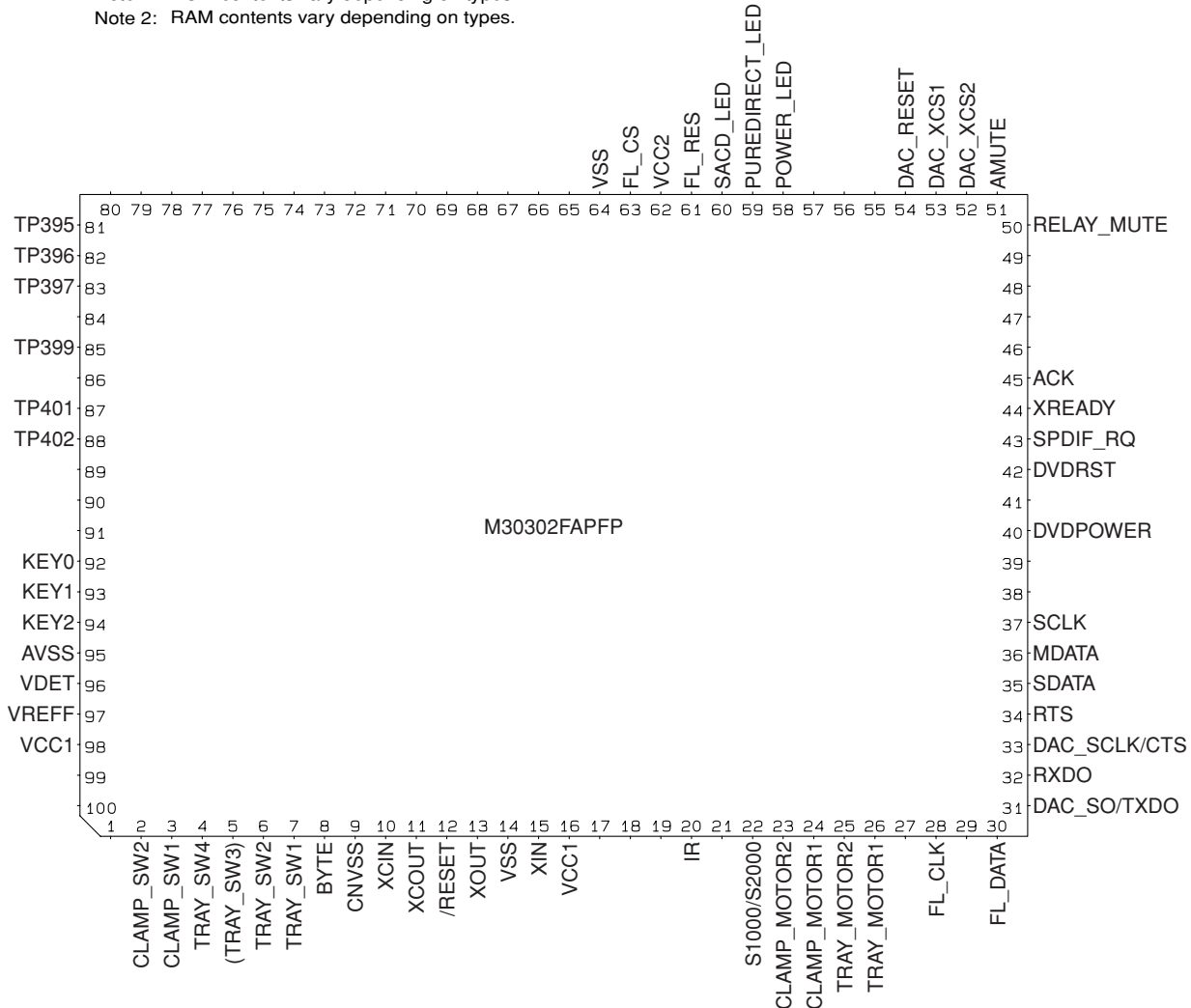

No.	Port Name	Function Name	I/O	Detail of Function
1	P9_6/ANEX1			(No connected)
2	P9_5/ANEX0	CLAMP_SW2	I	Clamp SW2
3	P9_4	CLAMP_SW1	I	Clamp SW1
4	P9_3	TRAY_SW4		
5	P9_2/TB2IN	TRAY_SW3	I	Tray SW3 / Loader mechanism specification confirm
6	P9_1/TB1IN	TRAY_SW2	I	Tray SW2
7	P9_0/TB0IN	TRAY_SW1	I	Tray SW1
8	BYTE		I	GND
9	CNVSS			Usually GND but VCC1 when writing FLASH
10	P8_7/XCIN			(No connected)
11	P8_6/XCOUT			(No connected)
12	/RESET	/RESET		
13	XOUT	XOUT		
14	VSS	VSS		GND
15	XIN	XIN		
16	VCC1	VCC1		
17	P8_5/NMI			Pull-up resistor required
18	P8_4/INT2			GND when writing FLASH
19	P8_3/INT1			(No connected)
20	P8_2/INT0	IR	I	Remote control
21	P8_1			(No connected)
22	P8_0	S1000/S2000		
23	P7_7	CLAMP_MOTOR2	O	Clamp motor 2
24	P7_6	CLAMP_MOTOR1	O	Clamp motor 1
25	P7_5/TA2IN	TRAY_MOTOR2	O	Tray motor 2
26	P7_4/TA2OUT	TRAY_MOTOR1	O	Tray motor 1
27	P7_3/CTS2/RTS2/TA1IN			(No connected)
28	P7_2/CLK2/TA1OUT	FL_CLK	O	FL control
29	P7_1/RXD2/SCL2/TA0IN			(No connected)
30	P7_0/TXD2/SDA2/TA0OUT	FL_DATA	O	FL control
31	P6_7/TXD1/SDA1	DAC_SO	O	TxD for DAC control / Rewriting FLASH commonly used
32	P6_6/RXD1/SCL1	RXDO	I	RxD for rewriting FLASH commonly used
33	P6_5/CLK1	DAC_SCLK	O	CTS for DAC control / Rewriting FLASH commonly used
34	P6_4/CTS1/RTS1/CTS0/CLKS1	RTS	I	RTS for rewriting FLASH commonly used
35	P6_3/TXD0/SDA0	SDATA	O	MODULE control
36	P6_2/RXD0/SCL0	MDATA	I	MODULE control
37	P6_1/CLK0	SCLK	I	MODULE control
38	P6_0/CTS0/RTS0			(No connected)
39	P5_7/RDY/CLKOUT			(No connected)
40	P5_6/ALE	DVDPOWER	O	MODULE control
41	P5_5/HOLD			GND when writing FLASH
42	P5_4/HLDA	XDVDRST	O	MODULE control
43	P5_3/BCLK	SPDIF_RQ	O	MODULE control
44	P5_2/RD	XREADY	O	MODULE control
45	P5_1/WRH/BHE	ACK	I	MODULE control
46	P5_0/WRL/WR			VCC1 when writing FLASH
47	P4_7/CS3			(No connected)
48	P4_6/CS2			(No connected)
49	P4_5/CS1			(No connected)
50	P4_4/CS0	RELAY_MUTE	O	output RELAY
51	P4_3/A19	AMUTE	O	Analog mute
52	P4_2/A18	DAC_XCS2	O	DAC control
53	P4_1/A17	DAC_XCS1	O	DAC control
54	P4_0/A16	DAC_RESET	O	DAC control
55	P3_7/A15			(No connected)
56	P3_6/A14			(No connected)

No.	Port Name	Function Name	I/O	Detail of Function
57	P3_5/A13			(No connected)
58	P3_4/A12	POWER_LED	O	Indicator of power supply
59	P3_3/A11	PUREDIRECT_LED	O	Indicator of pure direct
60	P3_2/A10	SACD_LED	O	Indicator of SACD
61	P3_1/A9	FL_RES	O	FL control
62	VCC2			
63	P3_0/A8	FL_CS	O	FL control
64	VSS	GND		
65	P2_7/A7			(No connected)
66	P2_6/A6			(No connected)
67	P2_5/A5			(No connected)
68	P2_4/A4			(No connected)
69	P2_3/A3			(No connected)
70	P2_2/A2			(No connected)
71	P2_1/A1			(No connected)
72	P2_0/A0			(No connected)
73	P1_7/D15			(No connected)
74	P1_6/D14/INT4			(No connected)
75	P1_5/D13/INT3			(No connected)
76	P1_4/D12			(No connected)
77	P1_3/D11			(No connected)
78	P1_2/D10			(No connected)
79	P1_1/D9			(No connected)
80	P1_0/D8			(No connected)
81	P0_7/AN0_7/D7	TP395	O	Test point
82	P0_6/AN0_6/D6	TP396	O	Test point
83	P0_5/AN0_5/D5	TP397	O	Test point
84	P0_4/AN0_4/D4	LOAD-	I	LOAD- monitor
85	P0_3/AN0_3/D3	TP399	O	Test point
86	P0_2/AN0_2/D2	LOAD+	I	LOAD+ monitor
87	P0_1/AN0_1/D1	TP401	O	Test point
88	P0_0/AN0_0/D0	TP402	O	Test point
89	P10_7/AN7/KI3			(No connected)
90	P10_6/AN6/KI2			(No connected)
91	P10_5/AN5/KI1			(No connected)
92	P10_4/AN4/KI0			(No connected)
93	P10_3/AN3	KEY0	I	Analog input
94	P10_2/AN2	KEY1	I	Analog input
95	P10_1/AN1	KEY2	I	Analog input
96	AVSS	GND		
97	P10_0/AN0	VDET	I	MODULE control
98	VREFF	VREFF		
99	AVCC	VCC1		
100	P9_7/ADTRG			(No connected)

Key detection for AD port

Key input (A/D) pull-up resistance 10 k-ohms

Ohm	+ 820	+ 3.3k	+ 12.0k
V	0 - 0.3	0.6 - 1.0	1.6 - 2.0
KEY0 (93 pin)	STOP	PAUSE	OPEN/CLOSE
KEY1 (94 pin)	PLAY	SEARCH+/SKIP+	SEARCH-/SKIP-
KEY2 (95 pin)	PURE DIRECT	SA-CD/CD	-

PIN CONNECTION DIAGRAMS



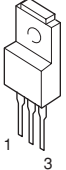
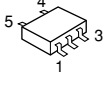
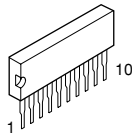
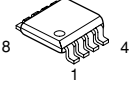
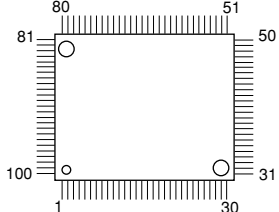
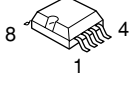
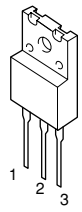
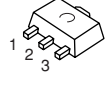
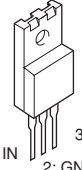
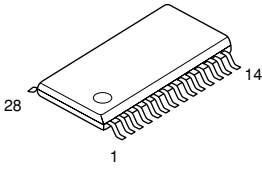
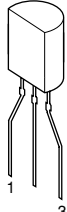
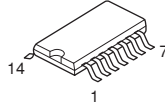
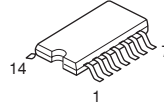
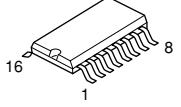
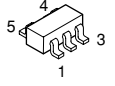
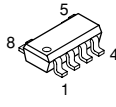

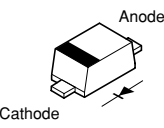
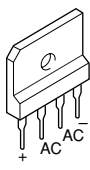
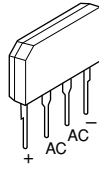
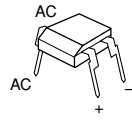

• ICs

<p>BA08CC0T</p> 	<p>BD4829G-TR</p> 	<p>LB1641</p> 	<p>LME49723MA</p> 	
<p>M30302FAPFP</p> 	<p>NE5532DR</p> 	<p>NJM7808FA</p>  <p>1: INPUT 2: GND 3: OUTPUT</p>	<p>NJM78L12UA</p>  <p>1: OUTPUT 2: GND 3: INPUT</p>	
<p>NJM78M05FA</p>  <p>1: IN 2: GND 3: OUT</p>	<p>PCM1796DBR</p> 	<p>PQ033ES3MXP</p> 	<p>TC74VHC08F</p> 	<p>TC74HCT08AF</p> 
<p>TC74VHC157F</p> 	<p>TC7SH08F TS7ST00F</p> 	<p>TC7WU04F</p> 		

• Diodes

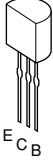
<p>1SS355 MA8030 3.0V MA8047-H 4.9V MA8056-M 5.6V MA8062-M 6.2V MA8082-L 7.9V MA8120-L 11.7V MA8300-M 30.0V RB501V-40</p> 	<p>D4SBN20-7101</p> 	<p>RS203M-B-C-J80</p> 	<p>S1NB20 1A 200V</p> 
---	---	---	---

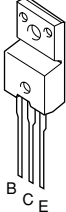
• Transistors

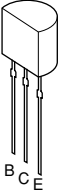
<p>2SA1037K</p> 	<p>2SA2168 2SC5291</p> 	<p>2SC2412K</p> 	<p>2SC2878</p> 	<p>2SA1312-GR,BL 2SD1938F 2SC3324-GR,BL</p> 
<p>2SD2014 SCA1725 2SC4511</p> 	<p>2SK208-Y</p> 	<p>DTA114EKA DTC114EKA</p>  <p>1: GND 2: IN 3: OUT</p>	<p>KTC3198</p> 	

BLOCK DIAGRAM

AUDIO

• See page 44 → SCHEMATIC DIAGRAM

LOADER UNIT

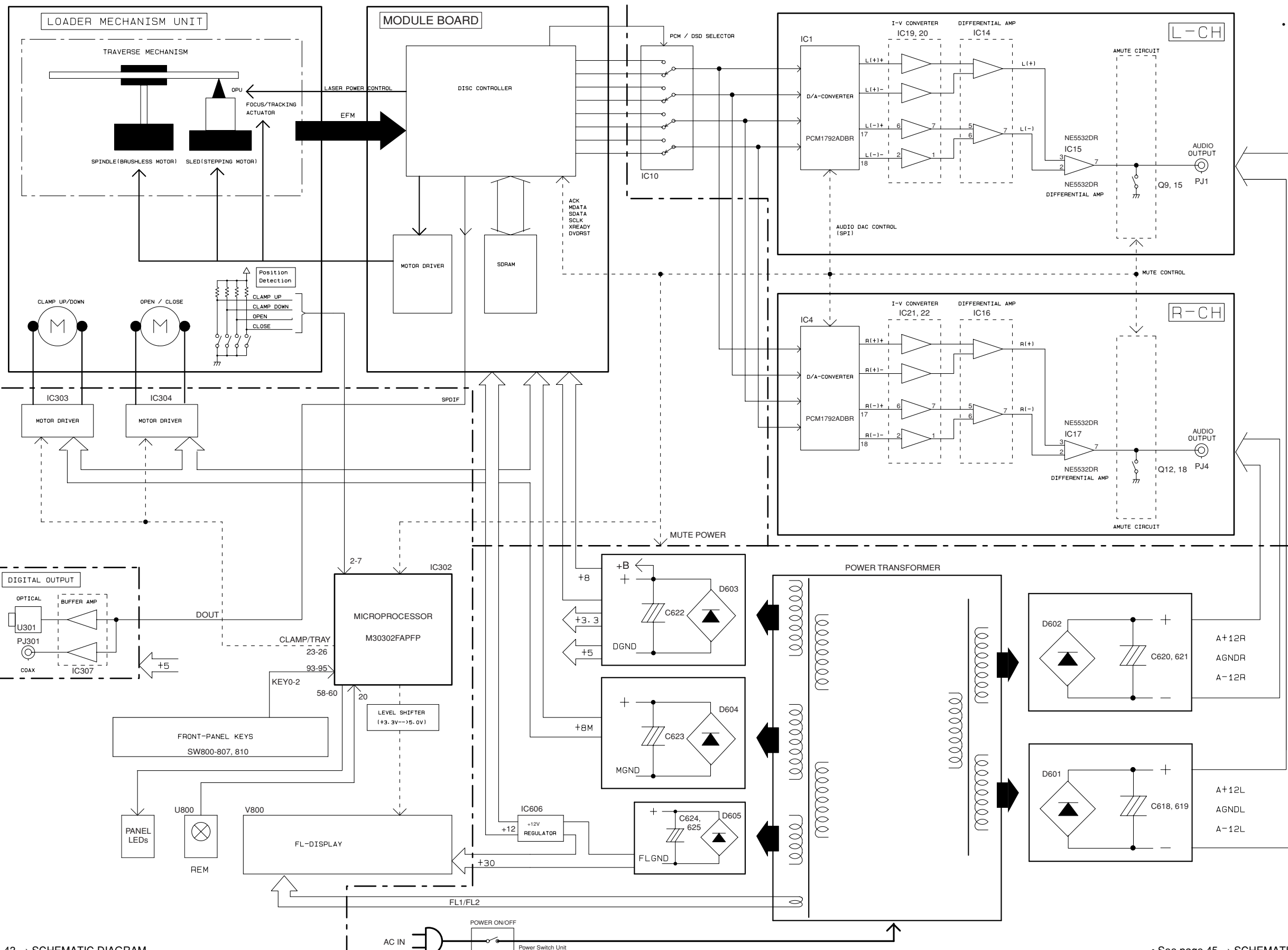

DIGITAL • See page 41-43 → SCHEMATIC DIAGRAM

• See page 45 → SCHEMATIC DIAGRAM **POWER**

PRINTED CIRCUIT BOARDS

DIGITAL (1) P.C.B. (Side A)

• Semiconductor Location

Ref no.	Location	Ref no.	Location
IC303	F5	IC304	G5

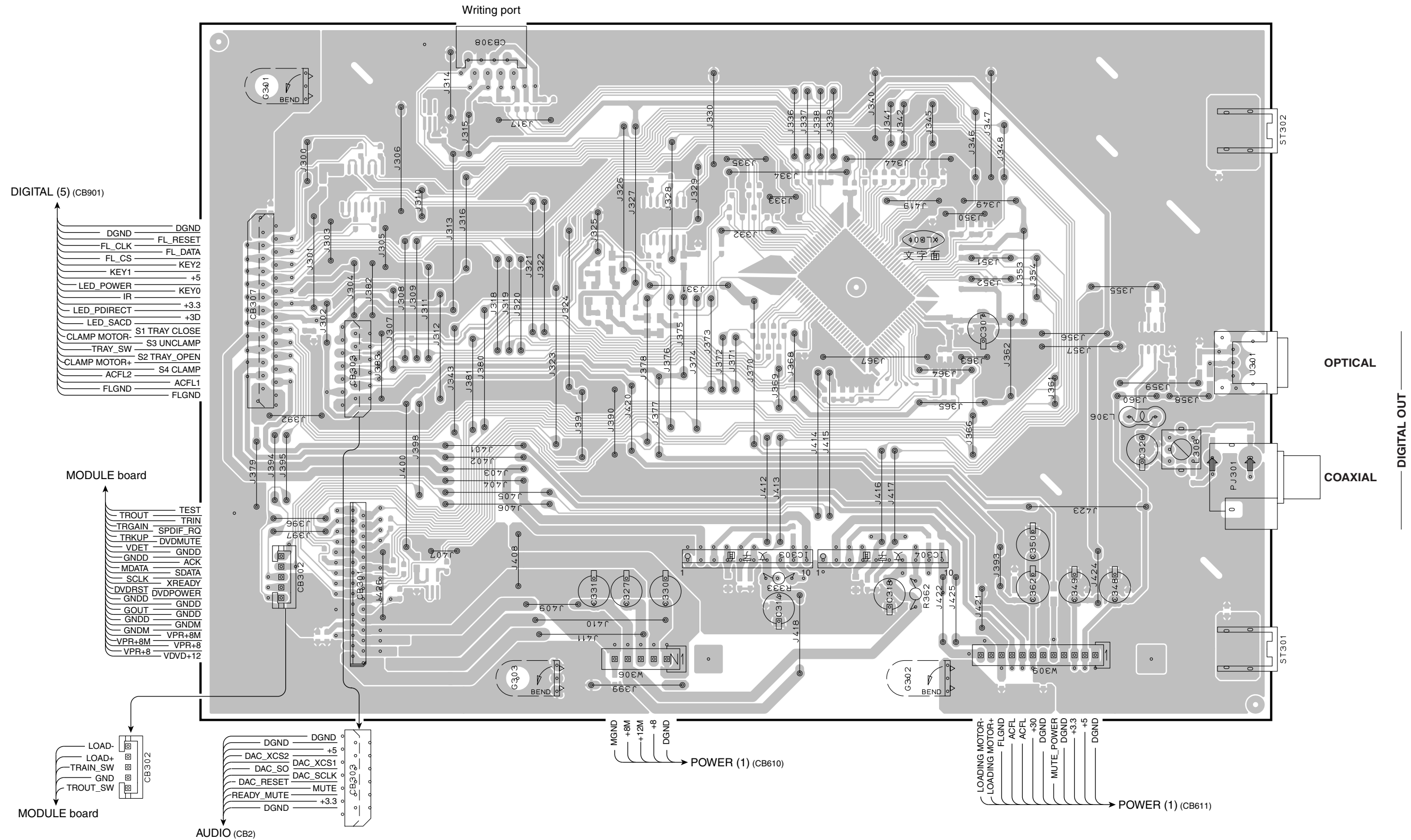

DIGITAL (5) (CB901)

- DGND
- FL_RESET
- FL_DATA
- KEY2
- KEY1
- +5
- KEY0
- +3.3
- +3D
- LED_POWER
- IR
- LED_PDIRECT
- LED_SACD
- S1 TRAY CLOSE
- S3 UNCLAMP
- TRAY_SW
- S2 TRAY_OPEN
- CLAMP MOTOR+
- S4 CLAMP
- ACFL2
- ACFL1
- FLGND
- FLGND

MODULE board

- TEST
- TRIN
- SPDIF_RQ
- DVDMUTE
- GND
- ACK
- SDATA
- XREADY
- DVDPOWER
- GND
- GND
- GND
- GND
- GND
- VPR+8M
- VPR+8
- VPR+8
- VDVD+12

MODULE board

AUDIO (CB2)

- DGND
- +5
- DAC_XCS2
- DAC_XCS1
- DAC_SO
- DAC_SCLK
- DAC_RESET
- MUTE
- READY_MUTE
- +3.3
- DGND

- MGND
 - +8M
 - +12M
 - +8
 - DGND
- POWER (1) (CB610)

- LOADING MOTOR-
 - LOADING MOTOR+
 - FLGND
 - ACFL
 - ACFL
 - +30
 - DGND
 - DGND
 - MUTE_POWER
 - DGND
 - +3.3
 - +5
 - DGND
- POWER (1) (CB611)

OPTICAL

COAXIAL

DIGITAL OUT

DIGITAL (1) P.C.B. (Side B)

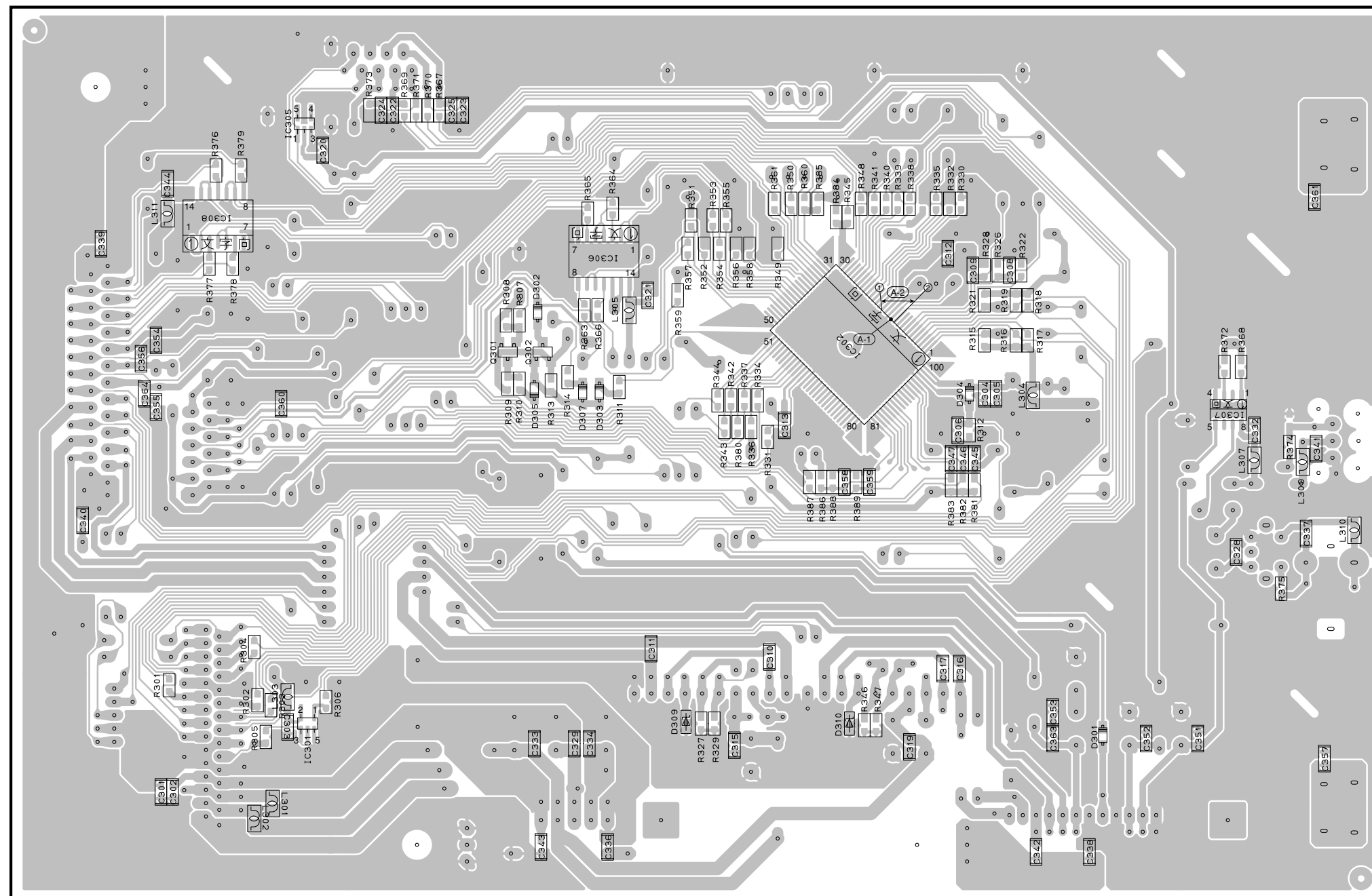

POINT (A-1) XL301 (Pin 13 of IC302)

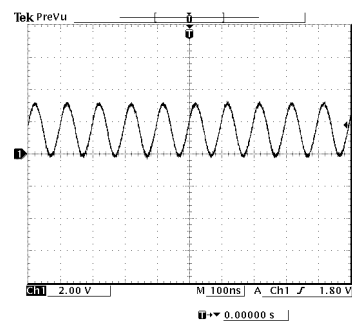

POINT (A-2) ①/ Pin 16, ②/ Pin 12 of IC302

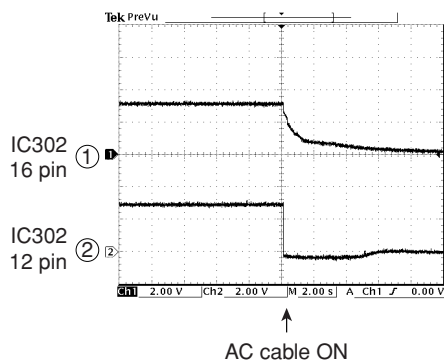
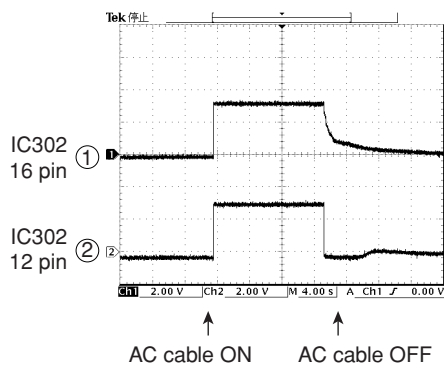

• **Semiconductor Location**

Ref no.	Location	Ref no.	Location
D301	H6	IC301	D5
D302	E3	IC302	F4
D303	E4	IC305	D3
D304	G4	IC306	E3
D305	E4	IC307	H4
D307	E4	IC308	C3
D309	F5	Q301	E4
D310	F5	Q302	E4

• Semiconductor Location

Ref no.	Location	Ref no.	Location
D801	C6	D803	G2
D802	D6		

DIGITAL (2) P.C.B. (Side A)

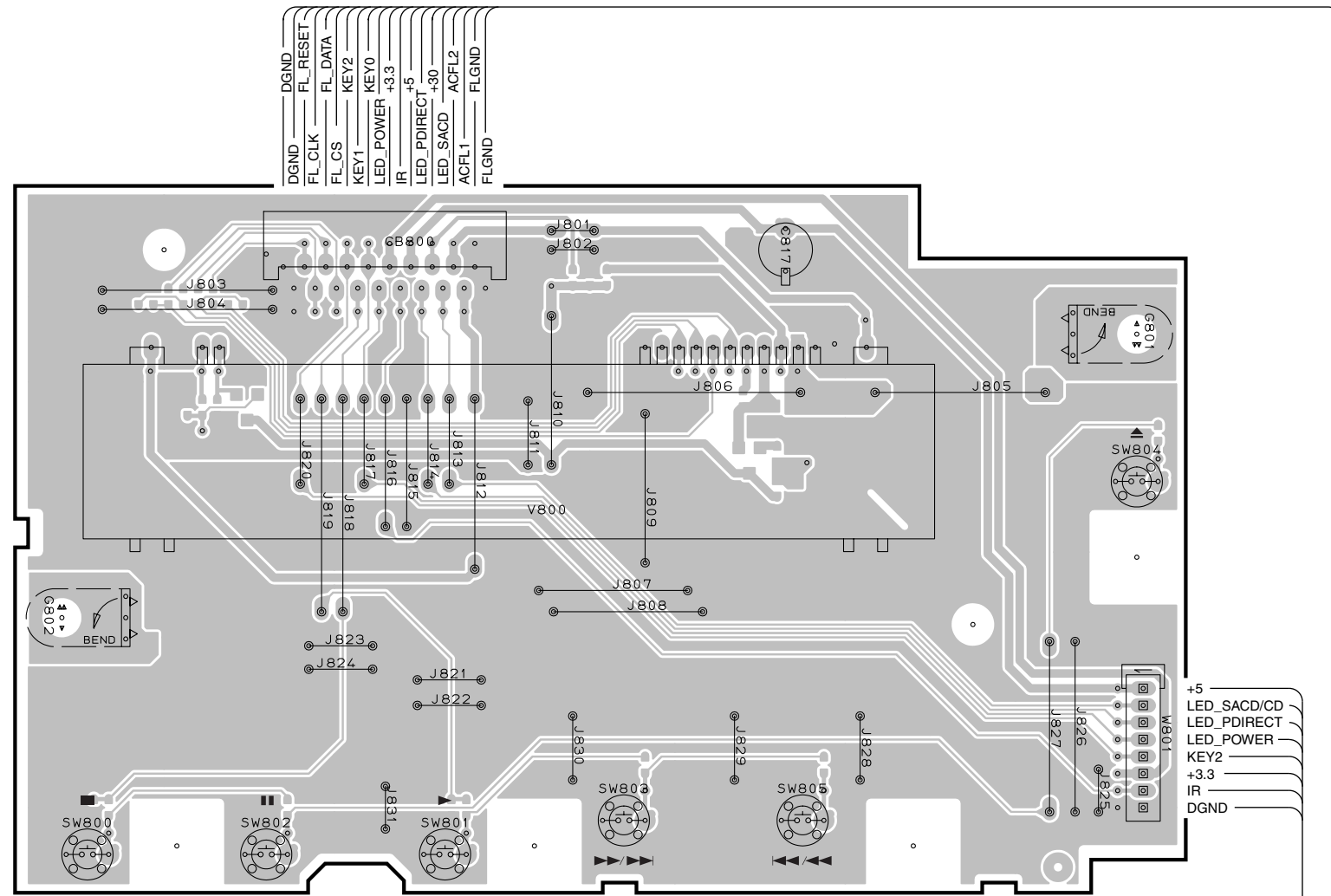

DIGITAL (3) P.C.B. (Side A)

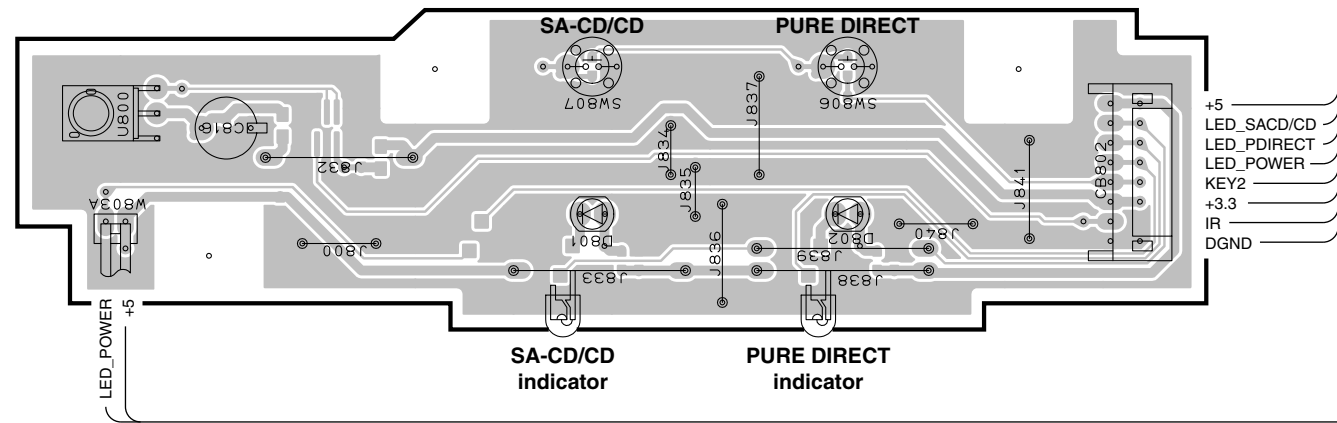

DIGITAL (4) P.C.B. (Side A)

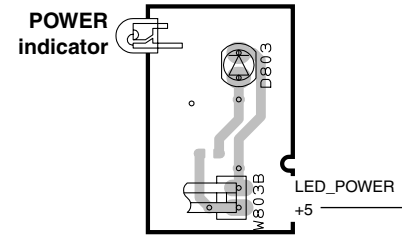

DIGITAL (6) P.C.B. (Side A)



DIGITAL (5) P.C.B. (Side A)

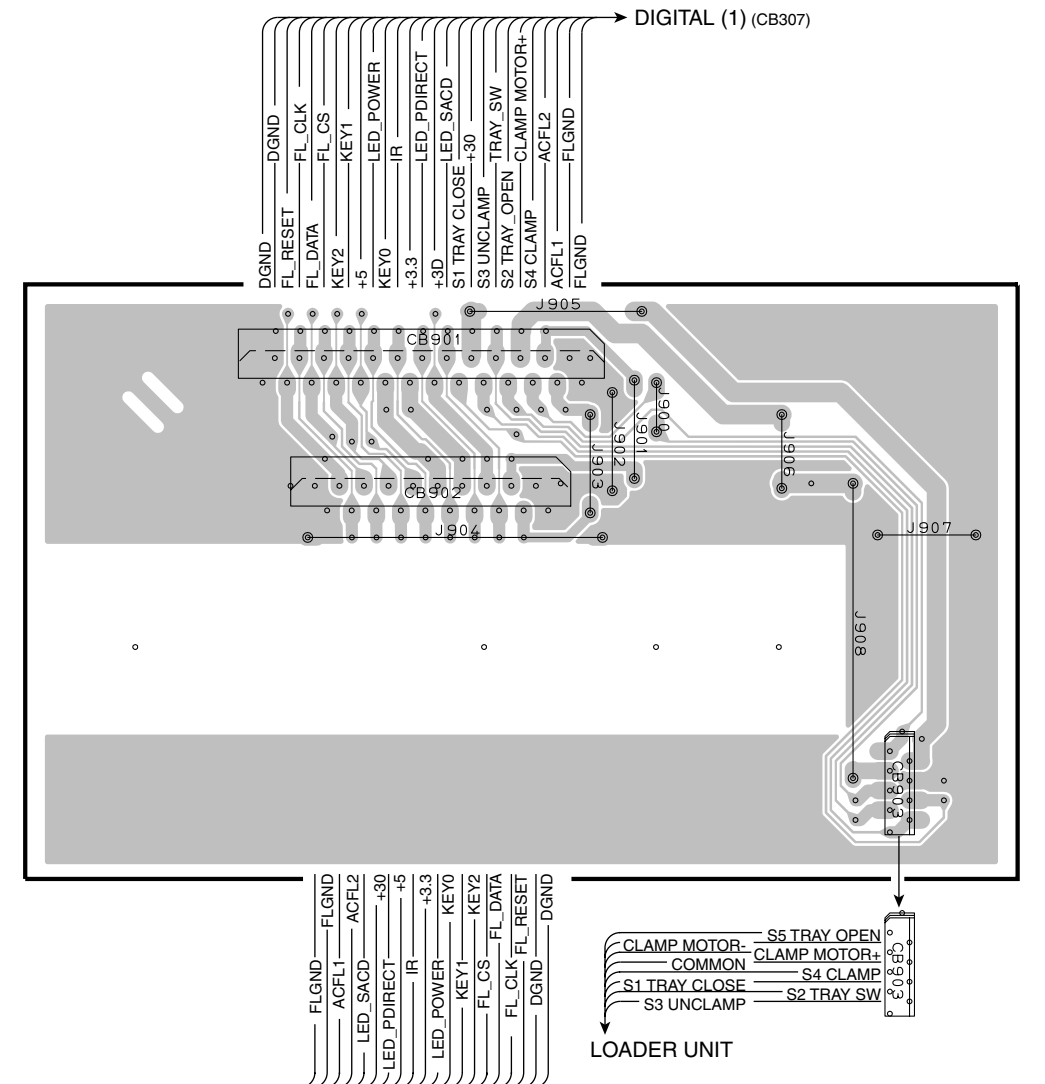

DIGITAL (2) P.C.B. (Side B)

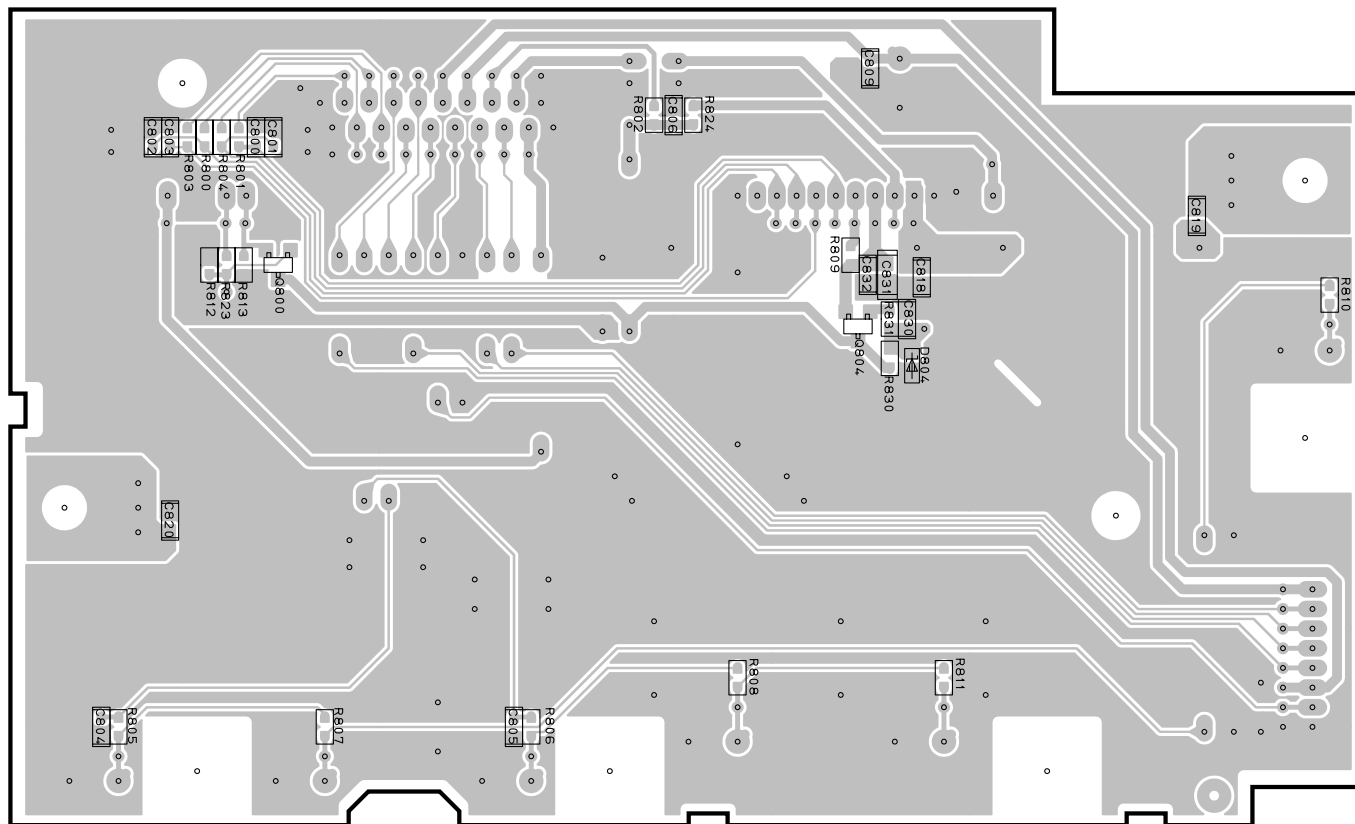

DIGITAL (3) P.C.B. (Side B)

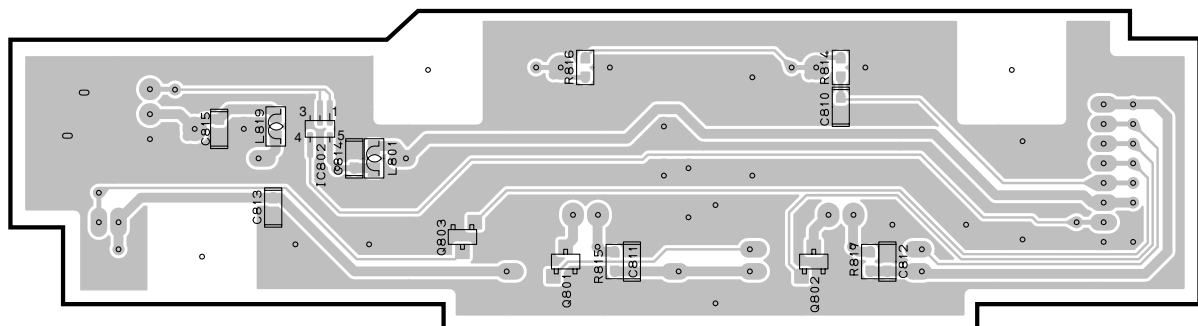

DIGITAL (4) P.C.B. (Side B)

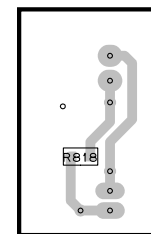

DIGITAL (6) P.C.B. (Side B)



DIGITAL (5) P.C.B. (Side B)

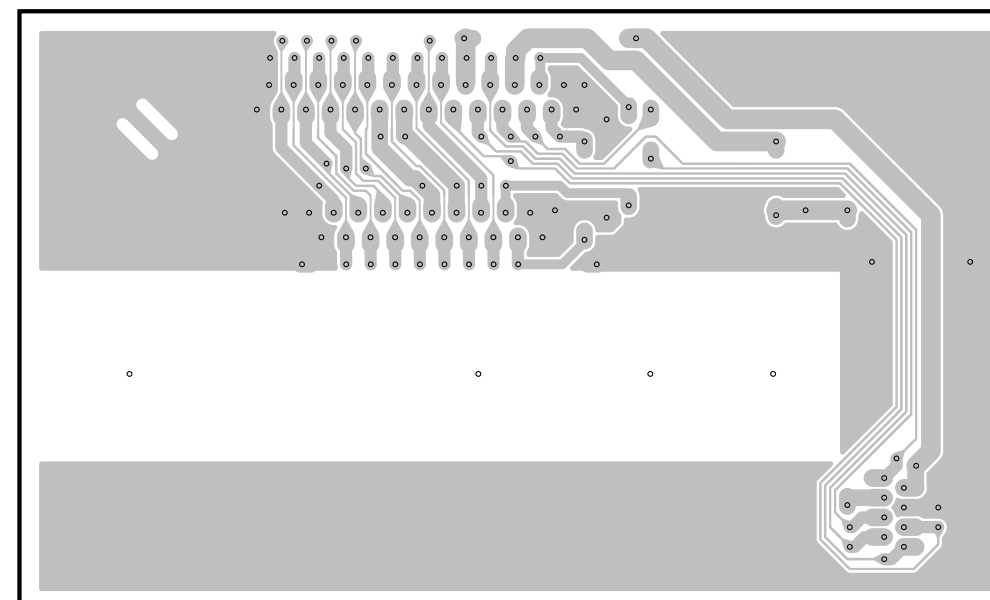

• **Semiconductor Location**

Ref no.	Location	Ref no.	Location
D804	D3	Q802	D7
IC802	B6	Q803	B7
Q800	B3	Q804	D3
Q801	C7		

AUDIO P.C.B. (Side A)

ANALOG OUT L

ANALOG OUT R

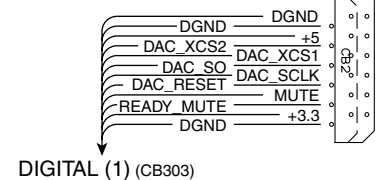
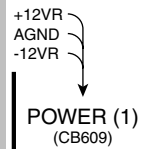
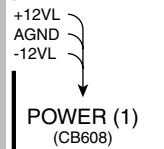
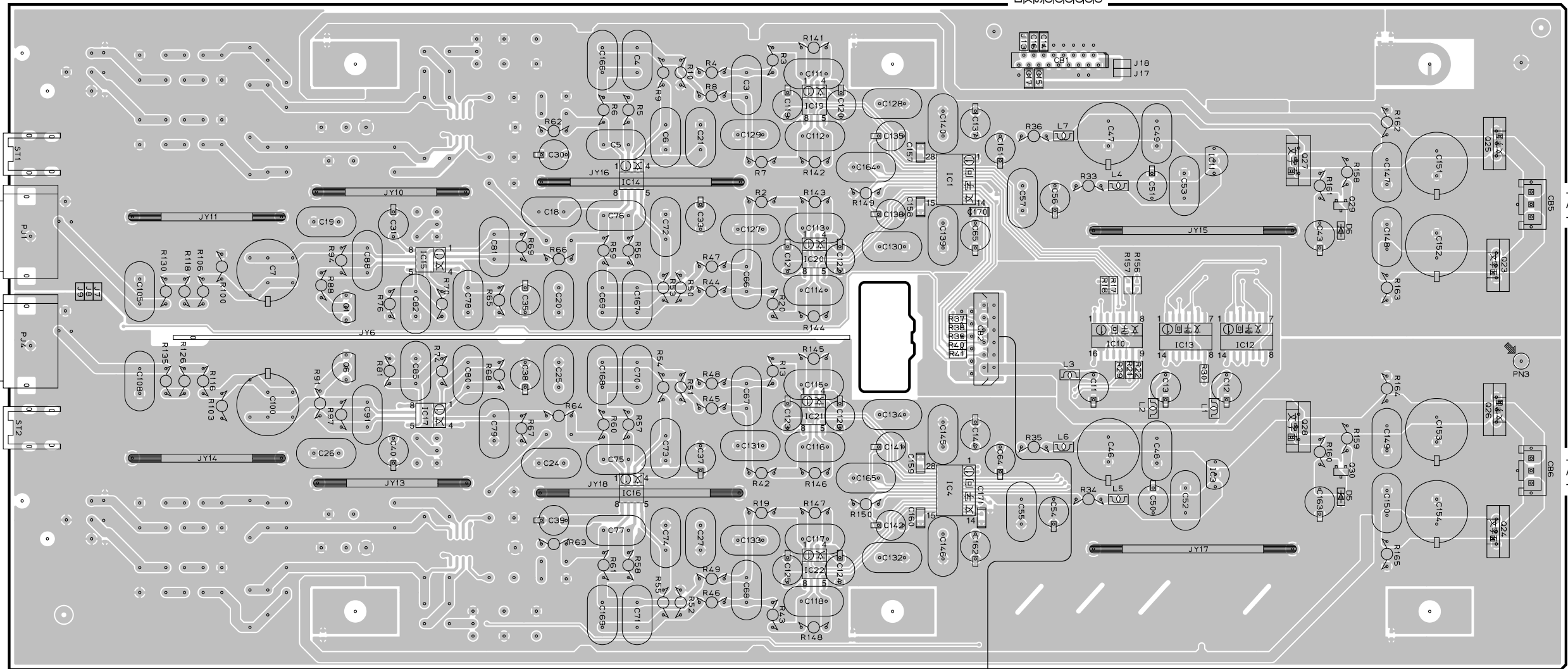
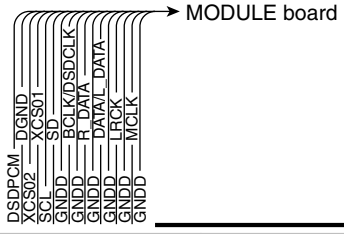

Semiconductor Location

Ref no.	Location	Ref no.	Location	Ref no.	Location	Ref no.	Location	Ref no.	Location
D5	I5	IC11	H4	IC17	D5	Q6	C5	Q28	H5
D6	I4	IC12	H5	IC19	F3	Q23	I4	Q29	I4
IC1	G4	IC13	H5	IC20	F4	Q24	I6	Q30	I5
IC4	G5	IC14	E4	IC21	F5	Q25	I4		
IC5	D6	IC15	D4	IC22	F6	Q26	I5		
IC10	G5	IC16	E5	Q1	C4	Q27	H4		

• Semiconductor Location

Ref no.	Location
D1	I4
D2	I4
D3	I5
D4	I5
Q2	H6
Q3	H6
Q9	C4
Q12	C5
Q15	C4
Q18	C5

AUDIO P.C.B. (Side B)

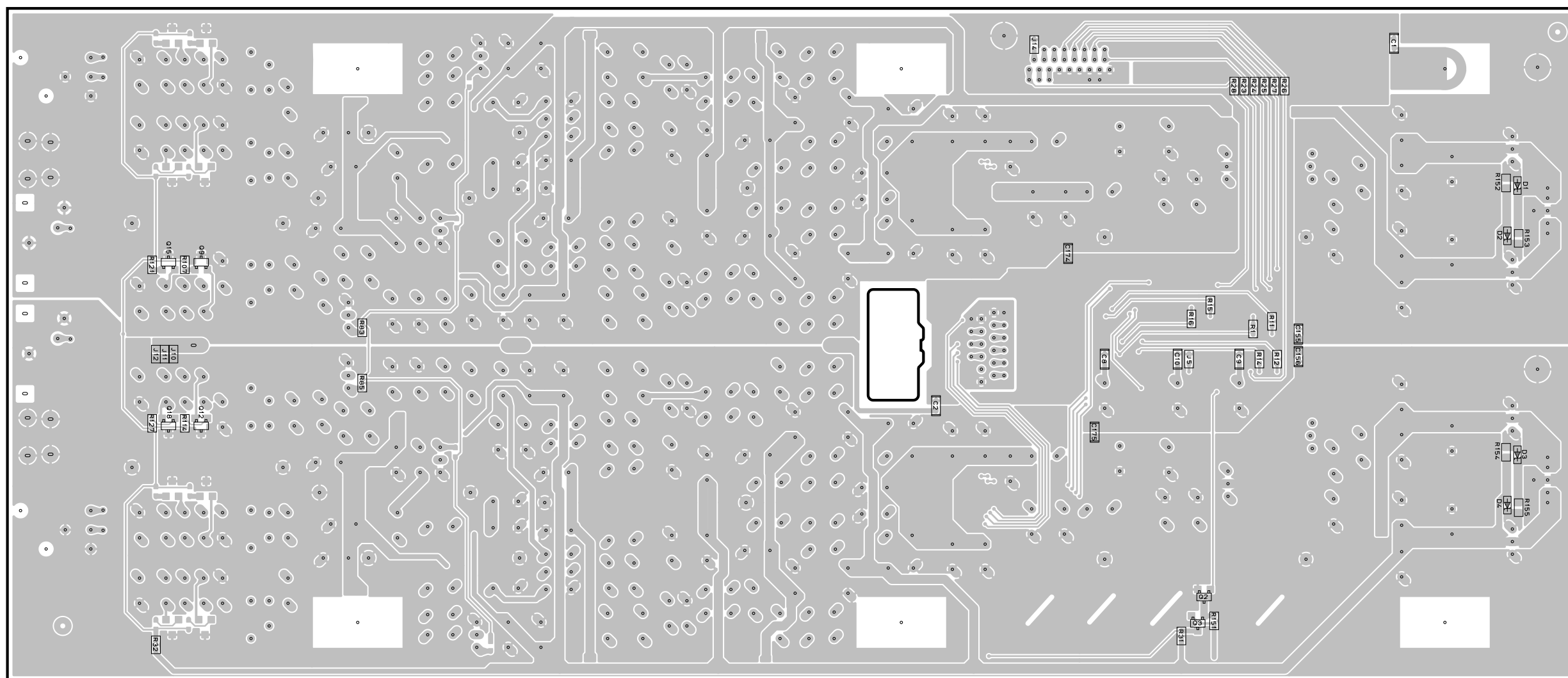

POWER (1) P.C.B. (Side A)

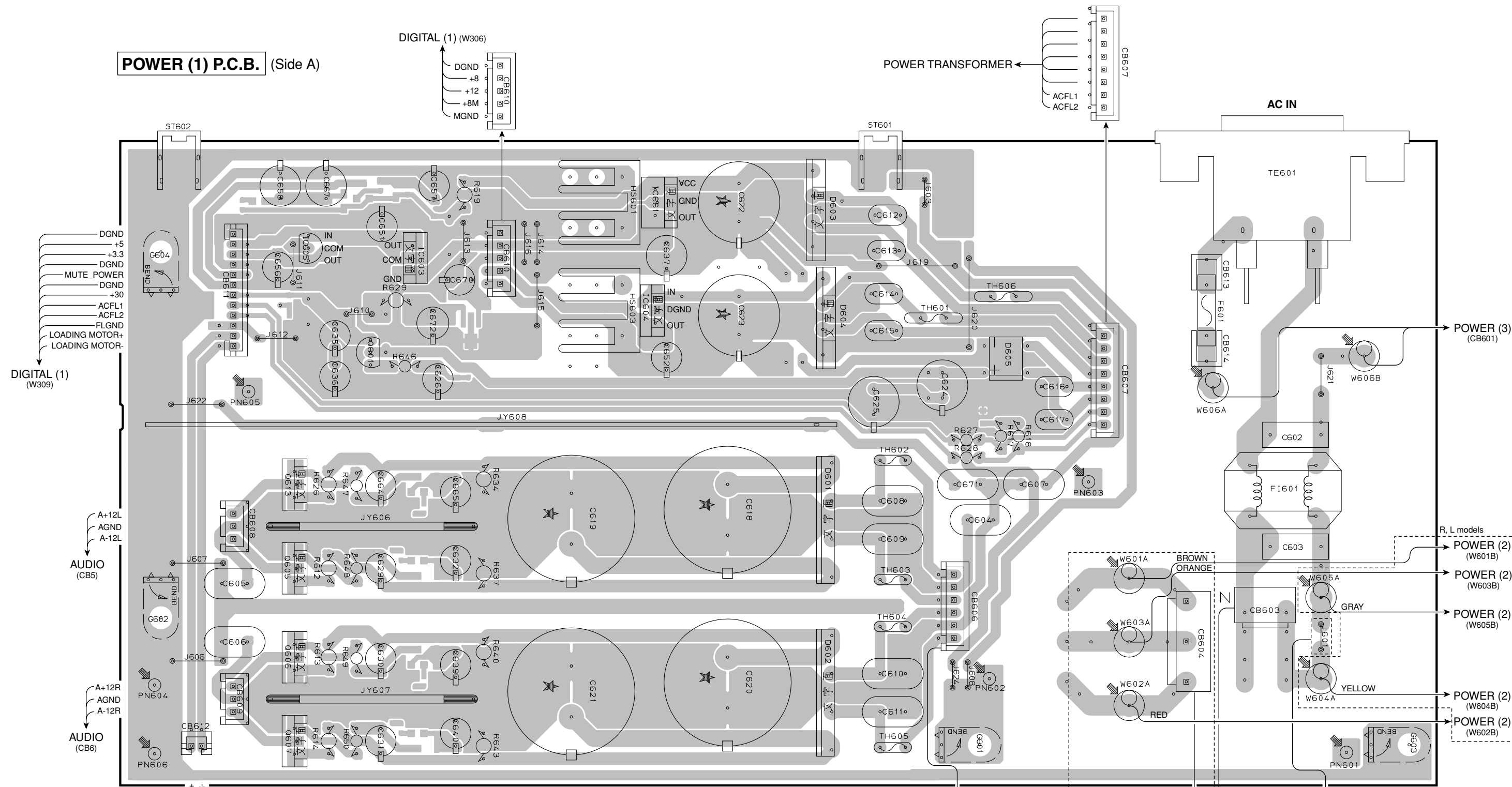

Semiconductor Location

Ref no.	Location	Ref no.	Location	Ref no.	Location
D601	F5	IC603	C3	Q605	C5
D602	F6	IC604	E3	Q606	C5
D603	F3	IC605	C3	Q607	C6
D604	F3	IC661	E3	Q613	C4
D605	G4	Q601	C4		

LOADER UNIT

POWER TRANSFORMER

POWER TRANSFORMER

POWER TRANSFORMER

POWER (1) P.C.B. (Side B)

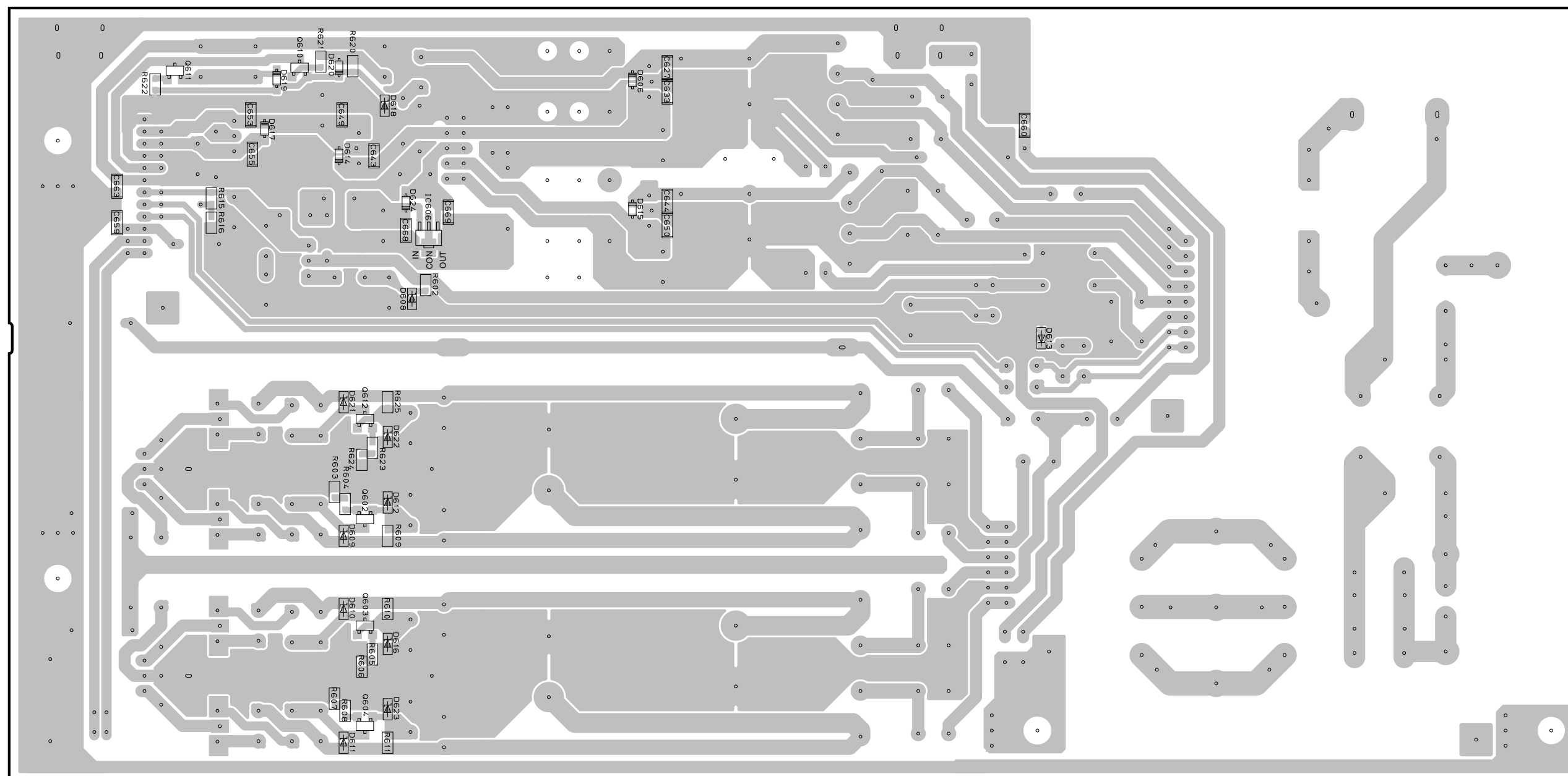

• **Semiconductor Location**

Ref no.	Location	Ref no.	Location	Ref no.	Location	Ref no.	Location	Ref no.	Location
D606	E3	D612	C5	D617	C3	D622	C4	Q603	C5
D608	D4	D613	G4	D618	C3	D623	C6	Q604	C6
D609	C5	D614	C3	D619	C3	D624	D3	Q610	C2
D610	C5	D615	E3	D620	C2	IC606	D3	Q611	B3
D611	C6	D616	C6	D621	C4	Q602	C5	Q612	C4

POWER (2) P.C.B. (Side A)

R, L models

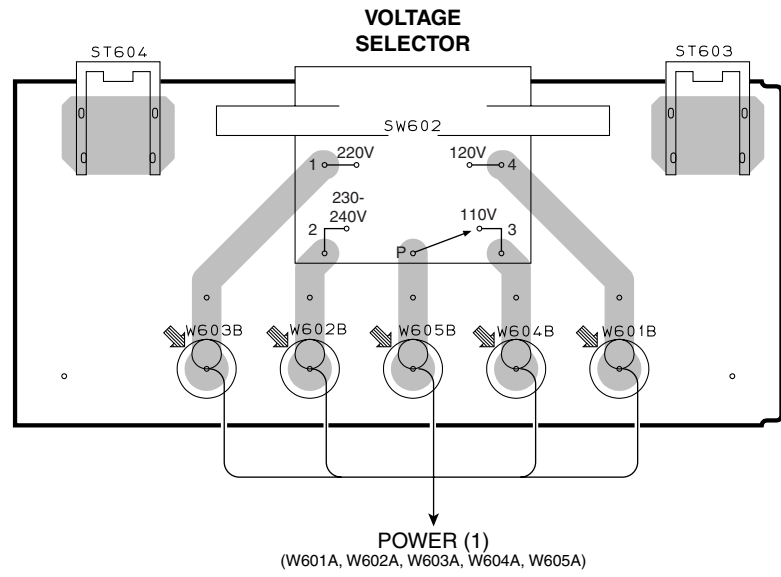

POWER (3) P.C.B. (Side A)

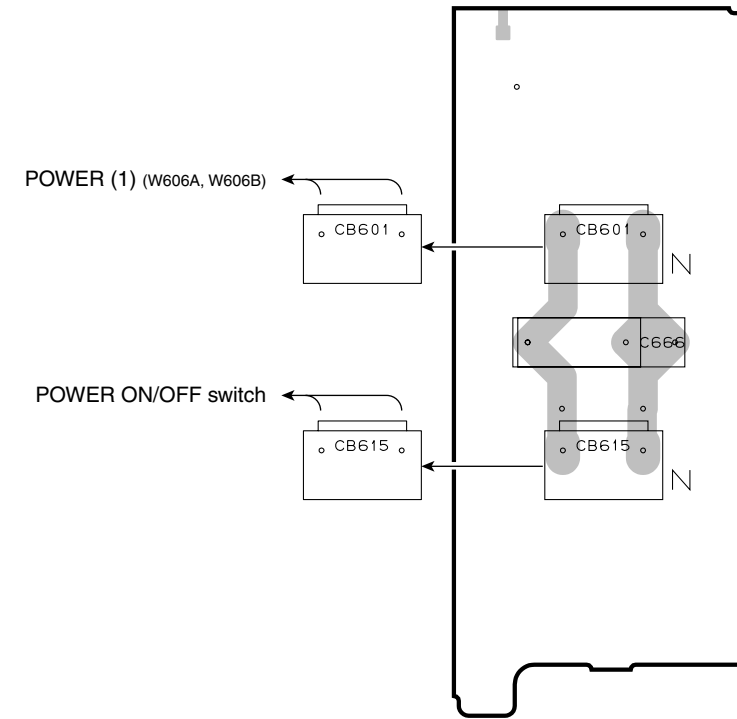

POWER (2) P.C.B. (Side B)

R, L models

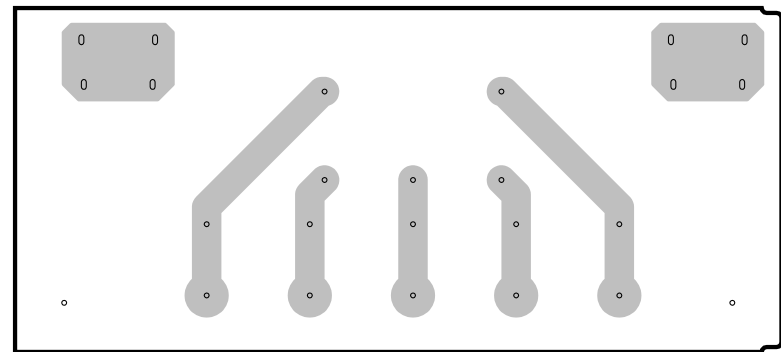

POWER (3) P.C.B. (Side B)

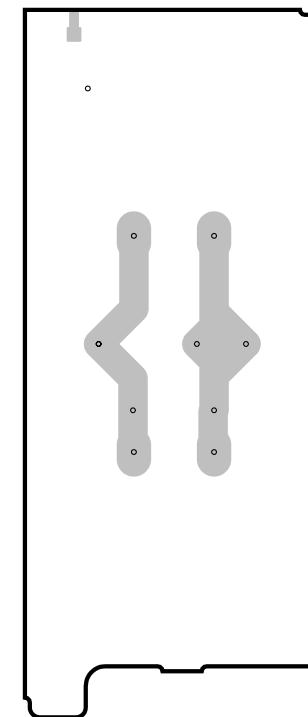

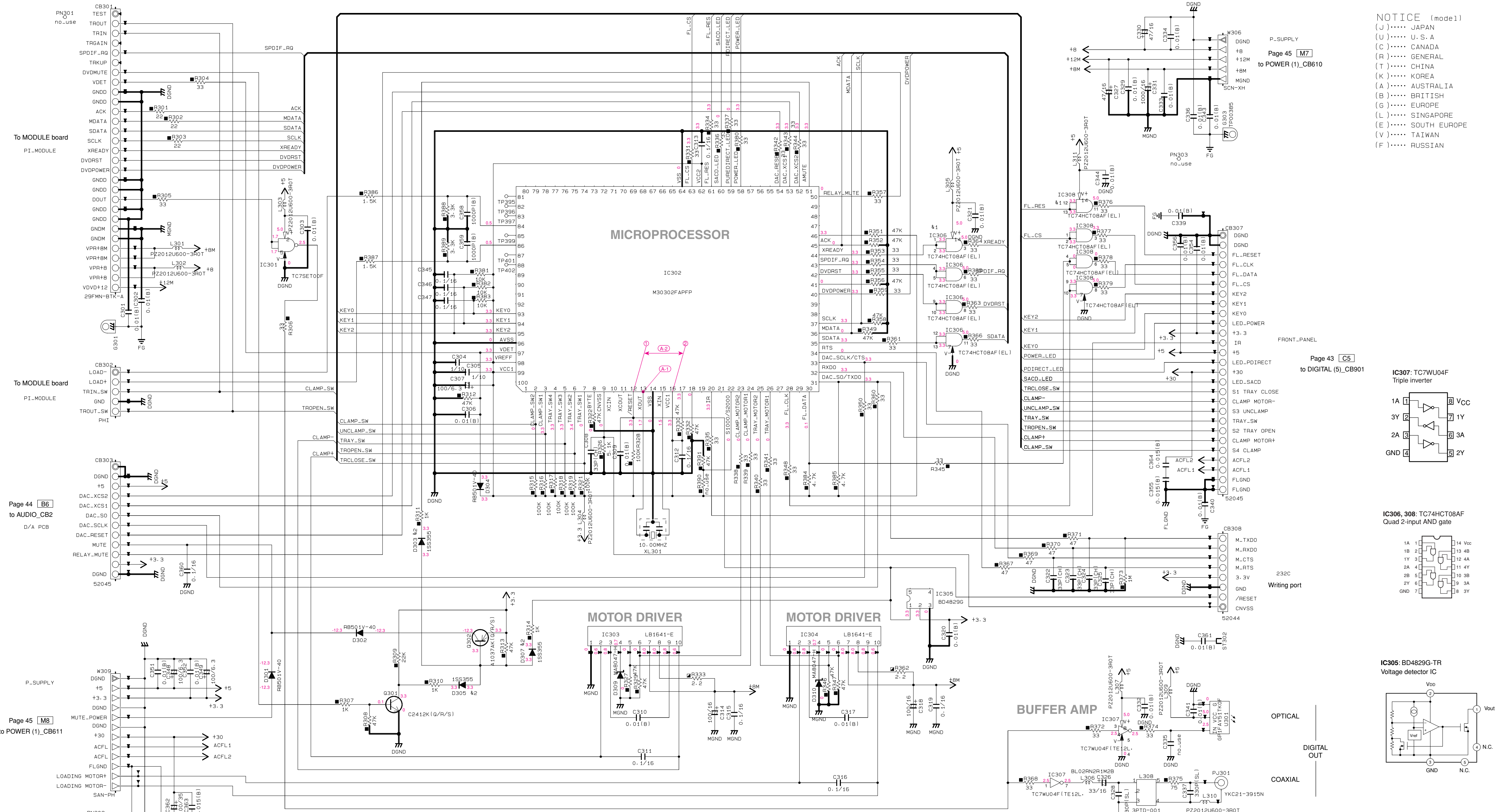

NOTICE (mode1)
(J)..... JAPAN
(U)..... U. S. A
(C)..... CANADA
(R)..... GENERAL
(T)..... CHINA
(K)..... KOREA
(A)..... AUSTRALIA
(B)..... BRITISH
(G)..... EUROPE
(L)..... SINGAPORE
(E)..... SOUTH EUROPE
(V)..... TAIWAN
(F)..... RUSSIAN

P_SUPPLY
Page 45 [M7]
to POWER (1)_CB610

Page 43 [C5]
to DIGITAL (5)_CB901

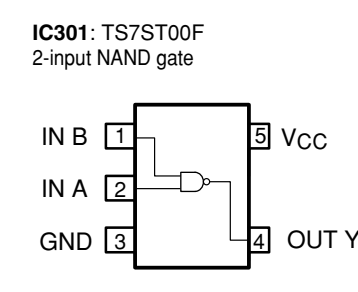
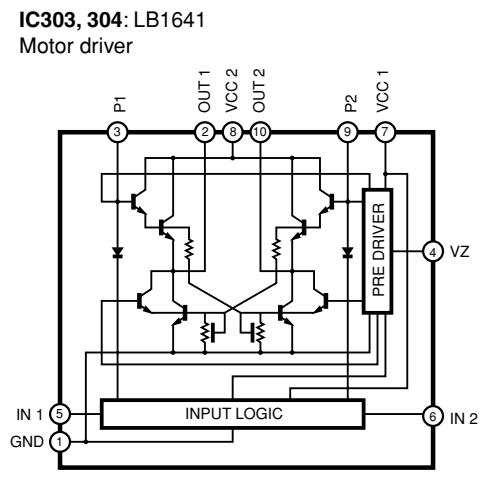
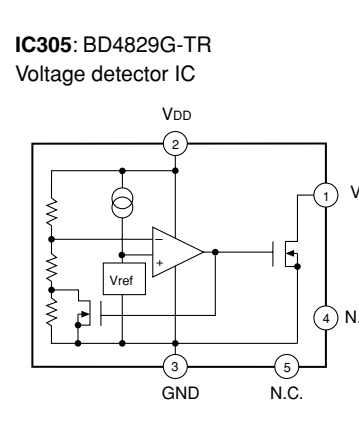
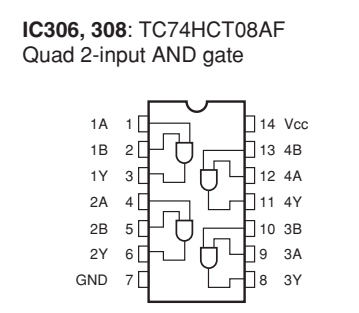
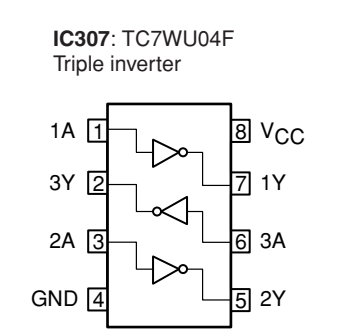

Interchangeable Parts at Manufacture-Stage

Mark	Reference Parts Number	Parts Name
&1	IC306-308	TC74HCT08AF NK74HCT08SJK NL
&2	D303-305-307	1SS355 MA141 KDS160-RTK/P

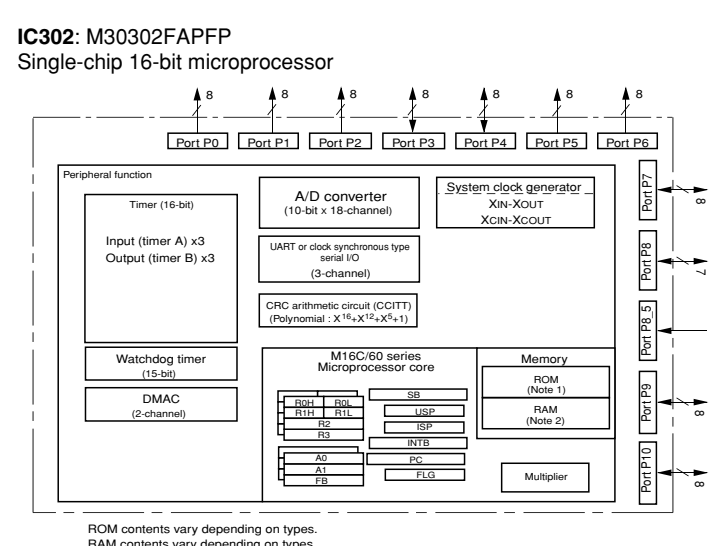
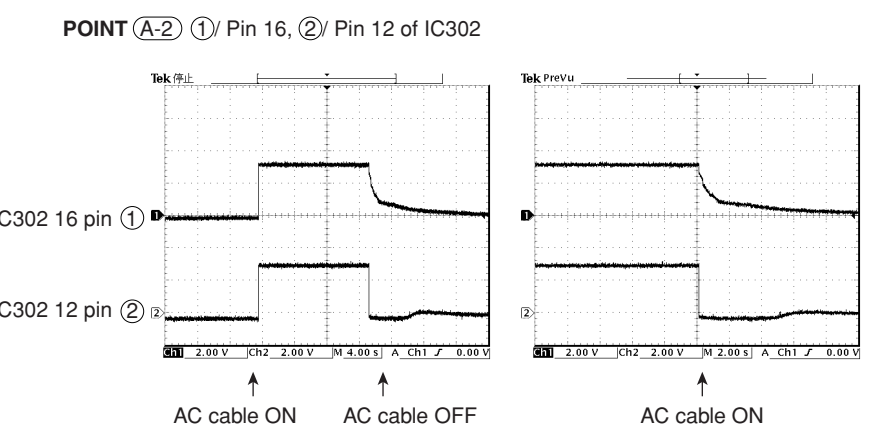
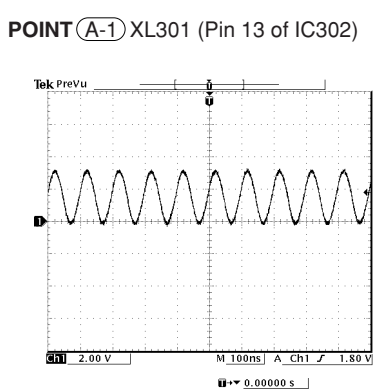

RESISTOR

REMARKS	PARTS NAME
NO MARK	CARBON FILM RESISTOR (P=5)
□	CARBON FILM RESISTOR (P=10)
△	METAL OXIDE FILM RESISTOR
⊠	METAL FILM RESISTOR
⊡	METAL PLATE RESISTOR
⊞	FIRE PROOF CARBON FILM RESISTOR
□	CEMENT MOLDED RESISTOR
⊙	SEMI VARIABLE RESISTOR
⊞	CHIP RESISTOR

CAPACITOR

REMARKS	PARTS NAME
NO MARK	ELECTROLYTIC CAPACITOR
⊗	TANTALUM CAPACITOR
NO MARK	CERAMIC CAPACITOR
⊙	CERAMIC TUBULAR CAPACITOR
⊚	POLYESTER FILM CAPACITOR
○	POLYSTYRENE FILM CAPACITOR
⊖	MICA CAPACITOR
⊕	POLYPROPYLENE FILM CAPACITOR
⊙	SEMICONDUCTIVE CERAMIC CAPACITOR

* All voltages are measured with a 10MΩ/V DC electronic voltmeter.
* Components having special characteristics are marked ⊠, and must be replaced with parts having specifications equal to those originally installed.
* Schematic diagram is subject to change without notice.
● 電圧は、内部抵抗10MΩの電圧計で測定したものです。
● ⊠印のある部品は、安全性確保部品を示しています。部品の交換が必要な場合、パーツリストに記載されている部品を使用してください。
● 本回路図は標準回路図です。改良のため予告なく変更することがございます。

DIGITAL 2/3

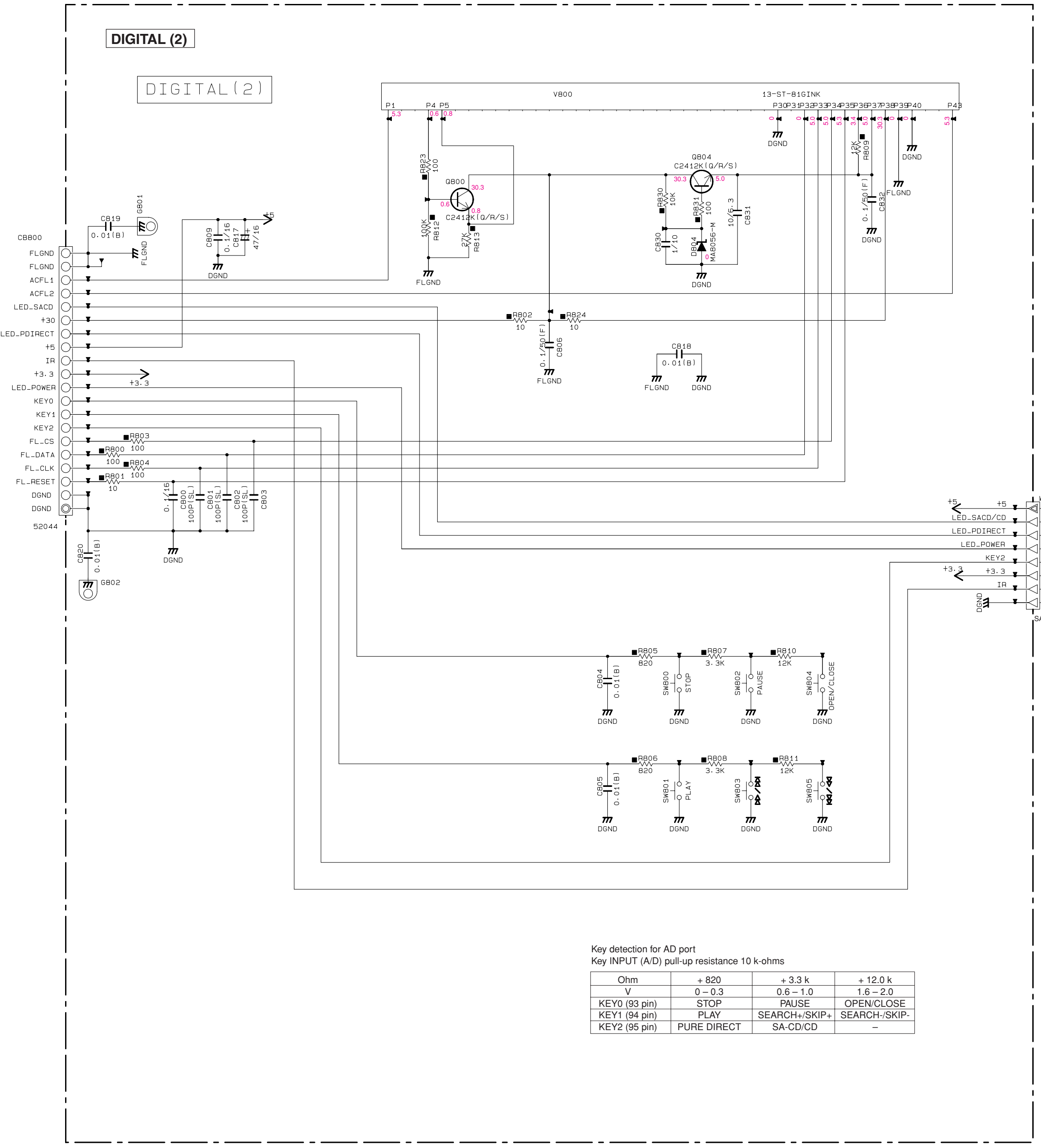

RESISTOR

REMARKS	PARTS NAME
NO MARK	CARBON FILM RESISTOR (P=5)
□	CARBON FILM RESISTOR (P=10)
△	METAL OXIDE FILM RESISTOR
▲	METAL FILM RESISTOR
⊠	METAL PLATE RESISTOR
▨	FIRE PROOF CARBON FILM RESISTOR
■	CEMENT MOLDED RESISTOR
▩	SEMI VARIABLE RESISTOR
■	CHIP RESISTOR

CAPACITOR

REMARKS	PARTS NAME
NO MARK	ELECTROLYTIC CAPACITOR
⊗	TANTALUM CAPACITOR
NO MARK	CERAMIC CAPACITOR
⊙	CERAMIC TUBULAR CAPACITOR
⊚	POLYESTER FILM CAPACITOR
○	POLYSTYRENE FILM CAPACITOR
⊖	MICA CAPACITOR
⊕	POLYPROPYLENE FILM CAPACITOR
⊗	SEMICONDUCTIVE CERAMIC CAPACITOR

Interchangeable Parts at Manufacture-Stage

Mark	Reference Parts Number	Parts Name
⊗11	Q801-B03	DTC114EKA KRC102S-RTK/P

NOTICE (mode1)

- (J)..... JAPAN
- (U)..... U.S.A
- (C)..... CANADA
- (R)..... GENERAL
- (T)..... CHINA
- (K)..... KOREA
- (A)..... AUSTRALIA
- (B)..... BRITISH
- (S)..... EUROPE
- (L)..... SINGAPORE
- (E)..... SOUTH EUROPE
- (V)..... TAIWAN
- (F)..... RUSSIAN

Page 43 H4
to DIGITAL (5)_CB902

Key detection for AD port
Key INPUT (A/D) pull-up resistance 10 k-ohms

Ohm	+ 820	+ 3.3 k	+ 12.0 k
V	0 - 0.3	0.6 - 1.0	1.6 - 2.0
KEY0 (93 pin)	STOP	PAUSE	OPEN/CLOSE
KEY1 (94 pin)	PLAY	SEARCH+ / SKIP+	SEARCH- / SKIP-
KEY2 (95 pin)	PURE DIRECT	SA-CD / CD	-

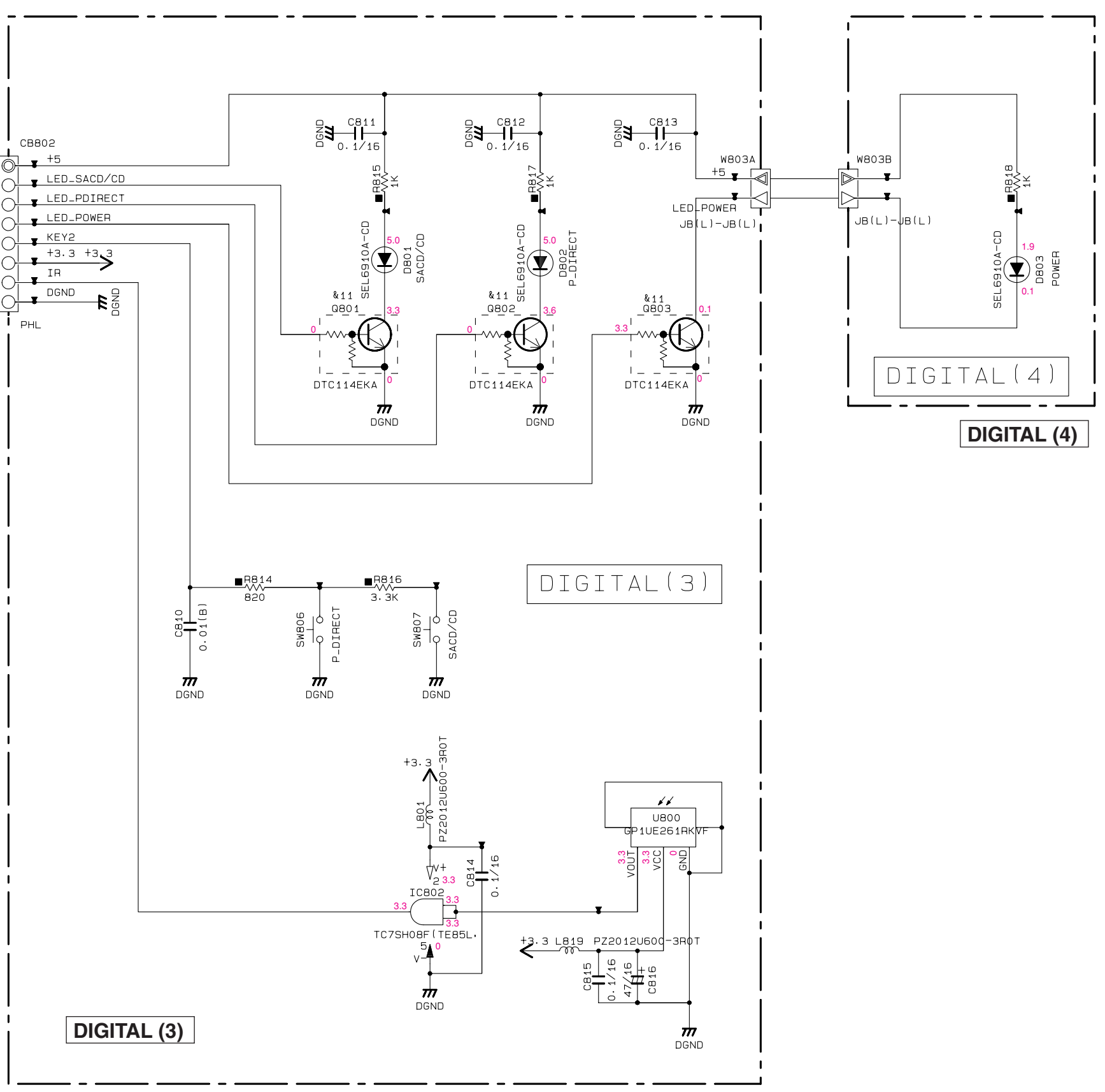

IC802: TC7SH08F
2-input AND gate

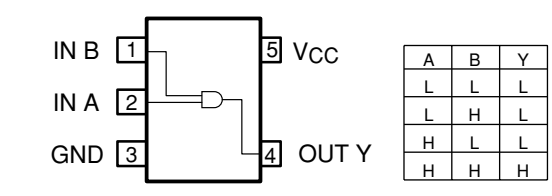

★ All voltages are measured with a 10MΩ/V DC electronic voltmeter.
★ Components having special characteristics are marked with a triangle and must be replaced with parts having specifications equal to those originally installed.
★ Schematic diagram is subject to change without notice.

● 電圧は、内部抵抗10MΩの電圧計で測定したものです。
● 三角形のある部品は、安全性確保部品を示しています。部品の交換が必要な場合、パーツリストに記載されている部品を使用してください。
● 本回路図は標準回路図です。改良のため予告なく変更することがございます。

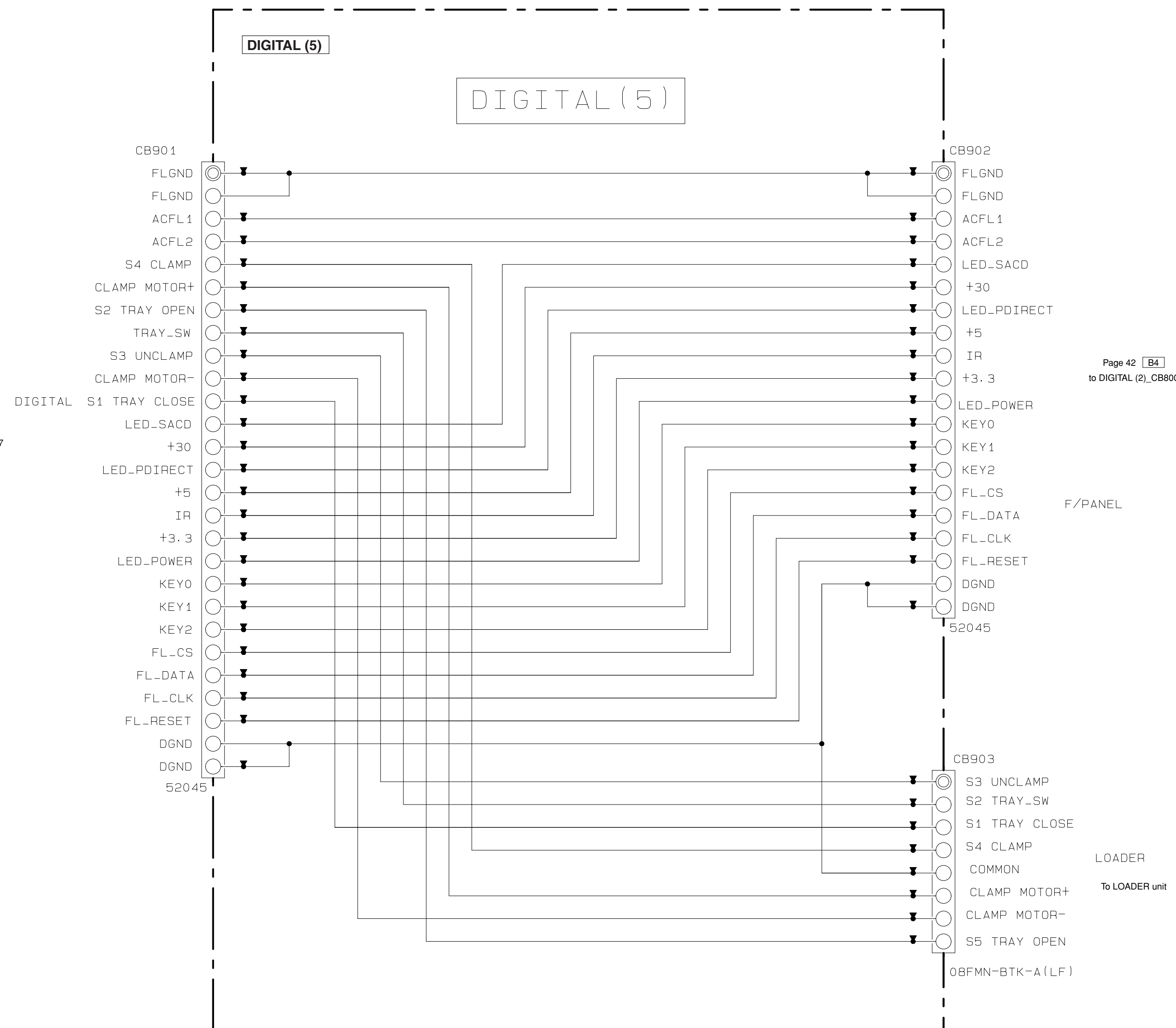

RESISTOR

REMARKS	PARTS NAME
NO MARK	CARBON FILM RESISTOR (P=5)
☒	CARBON FILM RESISTOR (P=10)
△	METAL OXIDE FILM RESISTOR
▲	METAL FILM RESISTOR
☒	METAL PLATE RESISTOR
☒	FIRE PROOF CARBON FILM RESISTOR
□	CEMENT MOLDED RESISTOR
⊙	SEMI VARIABLE RESISTOR
■	CHIP RESISTOR

CAPACITOR

REMARKS	PARTS NAME
NO MARK	ELECTROLYTIC CAPACITOR
⊗	TANTALUM CAPACITOR
NO MARK	CERAMIC CAPACITOR
●	CERAMIC TUBULAR CAPACITOR
◎	POLYESTER FILM CAPACITOR
○	POLYSTYRENE FILM CAPACITOR
⊖	MICA CAPACITOR
⊕	POLYPROPYLENE FILM CAPACITOR
⊗	SEMICONDUCTIVE CERAMIC CAPACITOR

NOTICE (model)

- (J)..... JAPAN
- (U)..... U. S. A
- (C)..... CANADA
- (R)..... GENERAL
- (T)..... CHINA
- (K)..... KOREA
- (A)..... AUSTRALIA
- (B)..... BRITISH
- (G)..... EUROPE
- (L)..... SINGAPORE
- (E)..... SOUTH EUROPE
- (V)..... TAIWAN
- (F)..... RUSSIAN

* All voltages are measured with a 10MΩ/V DC electronic voltmeter.
 * Components having special characteristics are marked ⊕ and must be replaced with parts having specifications equal to those originally installed.
 * Schematic diagram is subject to change without notice.
 ●電圧は、内部抵抗10MΩの電圧計で測定したものです。
 ⊕印のある部品は、安全性確保部品を示しています。部品の交換が必要な場合、パーツリストに記載されている部品を使用してください。
 ●本回路図は標準回路図です。改良のため予告なく変更することがございます。

AUDIO

Page 45 [J2] to POWER (1)_CB608

To MODULE board

Page 41 [B6] to DIGITAL (1)_CB303

Page 45 [J4] to POWER (1)_CB609

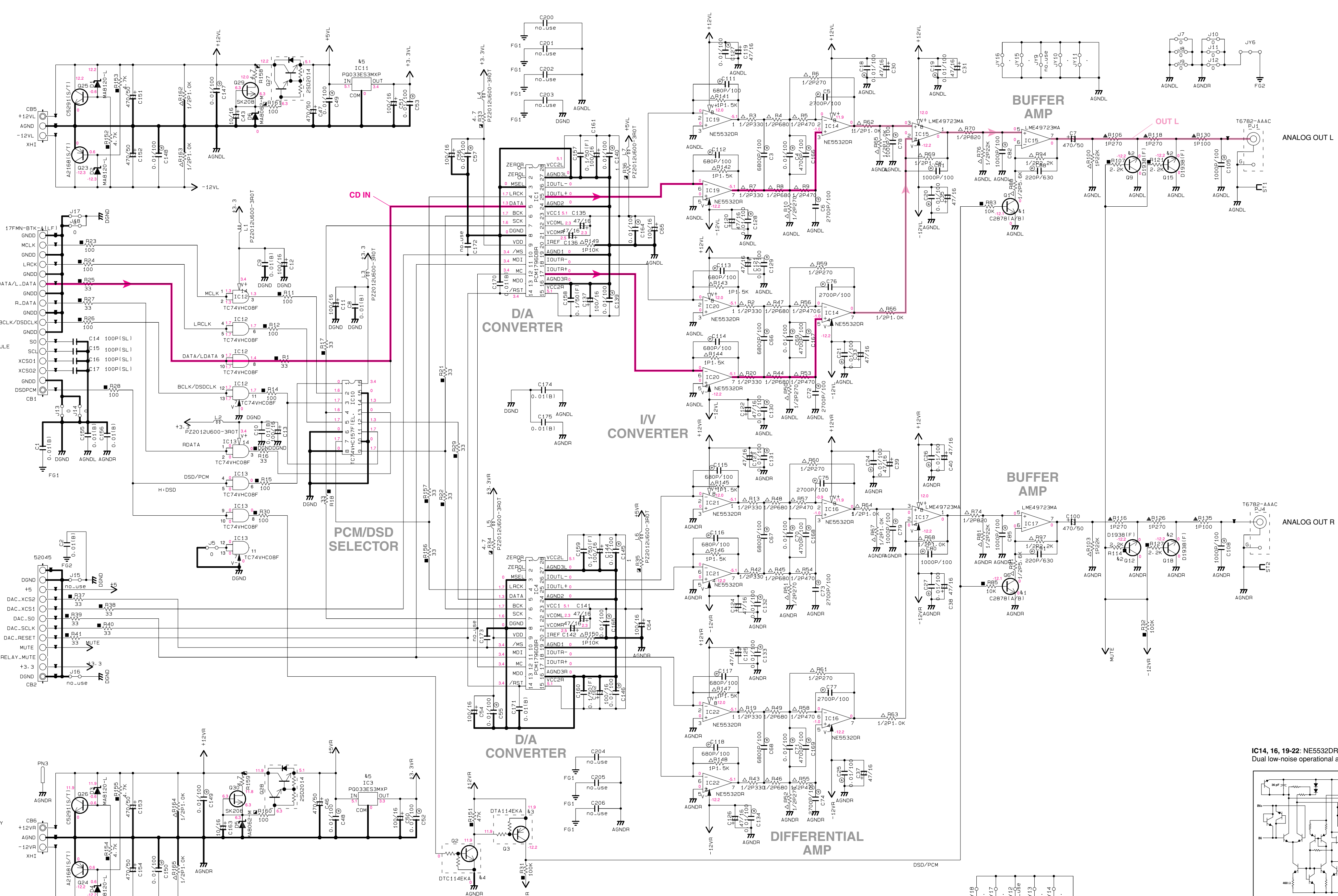

REMARKS	PARTS NAME	REMARKS	PARTS NAME
NO MARK	CARBON FILM RESISTOR (P=5)	NO MARK	ELECTROLYTIC CAPACITOR
[Z]	CARBON FILM RESISTOR (P=10)	[X]	TANTALUM CAPACITOR
[M]	METAL OXIDE FILM RESISTOR	[R]	GENERAL
[C]	CARBON FILM RESISTOR	[T]	CHINA
[K]	METAL PLATE RESISTOR	[K]	KOREA
[A]	FIRE PROOF CARBON FILM RESISTOR	[A]	AUSTRALIA
[B]	CEMENT MOLDED RESISTOR	[B]	BRITISH
[E]	SEMI VARIABLE RESISTOR	[G]	EUROPE
[S]	CHIP RESISTOR	[L]	SINGAPORE
		[E]	SOUTH EUROPE
		[V]	TAIWAN
		[F]	RUSSIAN

REMARKS	PARTS NAME
NO MARK	ELECTROLYTIC CAPACITOR
[X]	TANTALUM CAPACITOR
[C]	CERAMIC CAPACITOR
[T]	CERAMIC TUBULAR CAPACITOR
[P]	POLYESTER FILM CAPACITOR
[S]	POLYSTYRENE FILM CAPACITOR
[M]	MICA CAPACITOR
[P]	POLYPROPYLENE FILM CAPACITOR
[S]	SEMICONDUCTIVE CERAMIC CAPACITOR

NOTICE (model1)
 (J)..... JAPAN
 (U)..... U.S. A
 (C)..... CANADA
 (R)..... GENERAL
 (T)..... CHINA
 (K)..... KOREA
 (A)..... AUSTRALIA
 (B)..... BRITISH
 (G)..... EUROPE
 (L)..... SINGAPORE
 (E)..... SOUTH EUROPE
 (V)..... TAIWAN
 (F)..... RUSSIAN

Mark	Reference Parts Number	Parts Name
k1	01-6	2SC2878 A-B 2SD1915FSA S-T KTC2874-(A/B)
k2	09-12-15-18	2SD1938F1 2SC3326 A-B 2SC5938A A-B 2SD2704 K
k3	03	DTA114EKA KRA1025-RTK/P
k4	02	DTC114EKA KRC1025-RTK/P
k5	IC3-11	PQ033ES3MXP PQ033ES1MXP

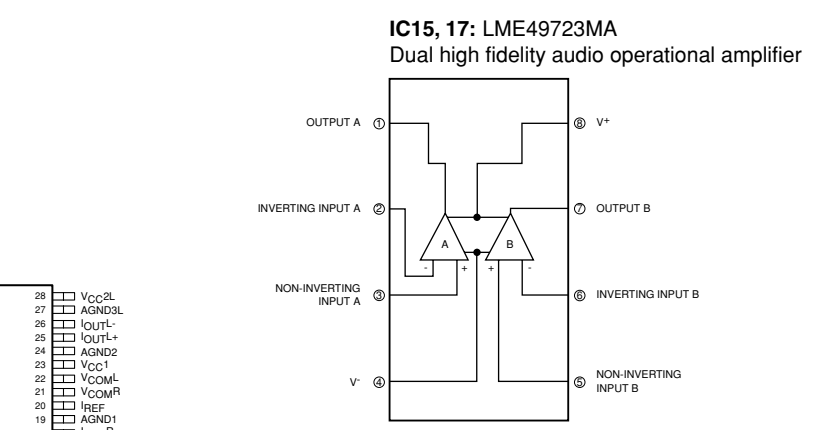
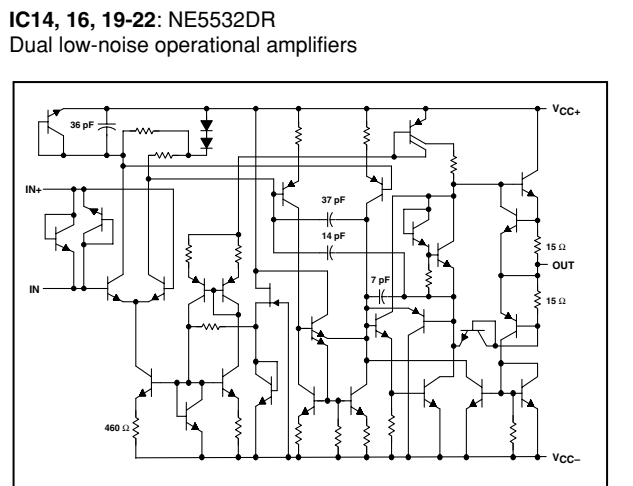
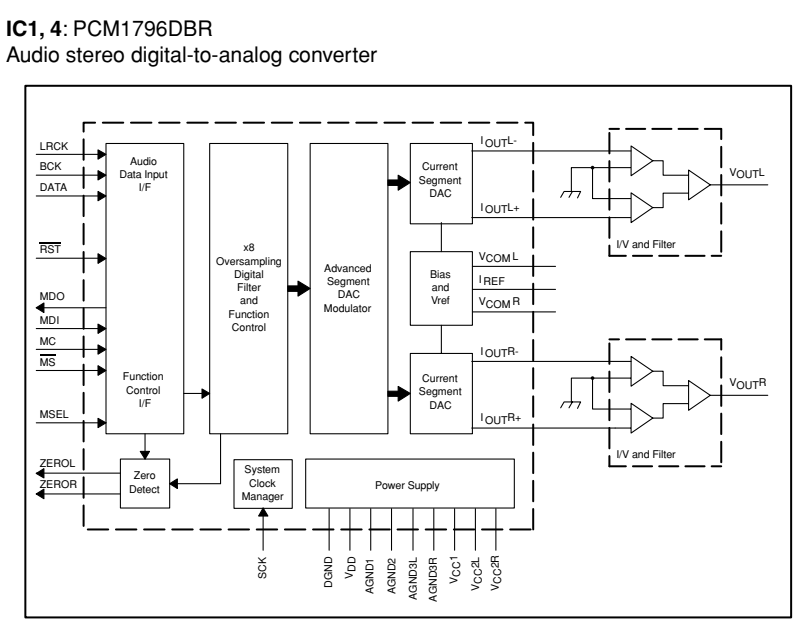

IC3, 11: PQ033ES3MXP Low power loss regulator

IC10: TC74VHC157F Quad 2-channel multiplexer

IC12, 13: TC74VHC08F Quad 2-input AND gate

IC14, 16, 19-22: NE5532DR Dual low-noise operational amplifiers

IC15, 17: LME49723MA Dual high fidelity audio operational amplifier

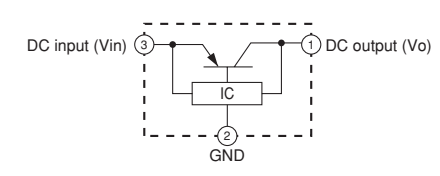

SELECT	1A	1B	1Y	2A	2B	2Y	GND	Inputs	Output
ST	X	X	X	X	X	X	X	A	B
X	X	X	X	X	X	X	X	L	H
X	X	X	X	X	X	X	X	L	H
X	X	X	X	X	X	X	X	L	H
X	X	X	X	X	X	X	X	L	H
X	X	X	X	X	X	X	X	L	H

1A	1B	1Y	2A	2B	2Y	GND	Inputs	Output
X	X	X	X	X	X	X	A	B
X	X	X	X	X	X	X	L	H
X	X	X	X	X	X	X	L	H
X	X	X	X	X	X	X	L	H
X	X	X	X	X	X	X	L	H
X	X	X	X	X	X	X	L	H

* All voltages are measured with a 10MΩ/V DC electronic voltmeter.
 * Components having special characteristics are marked with a triangle and must be replaced with parts having specifications equal to those originally installed.
 * Schematic diagram is subject to change without notice.

● 電圧は、内部抵抗10MΩの電圧計で測定したものです。
 ● 印のある部品は、安全性確保部品を示しています。部品の交換が必要な場合、パーツリストに記載されている部品を使用してください。
 ● 本回路図は標準回路図です。改良のため予告なく変更することがございます。

POWER

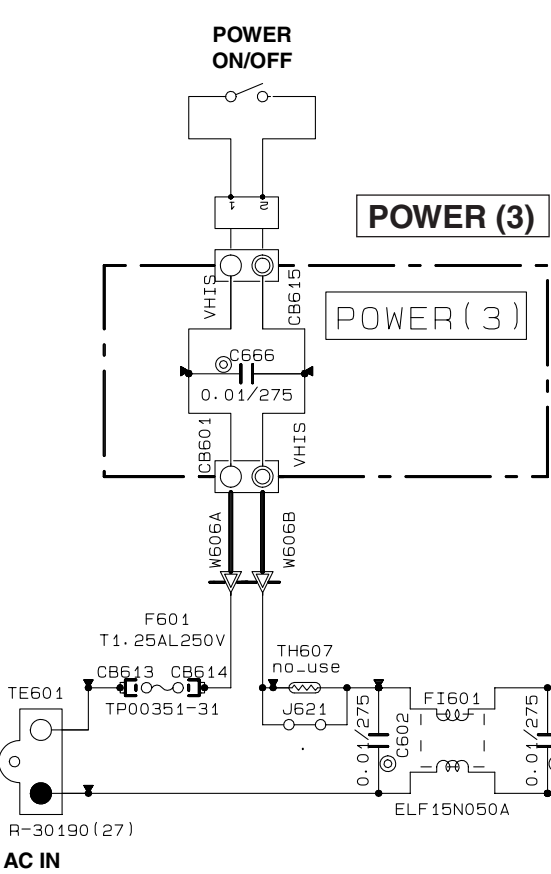
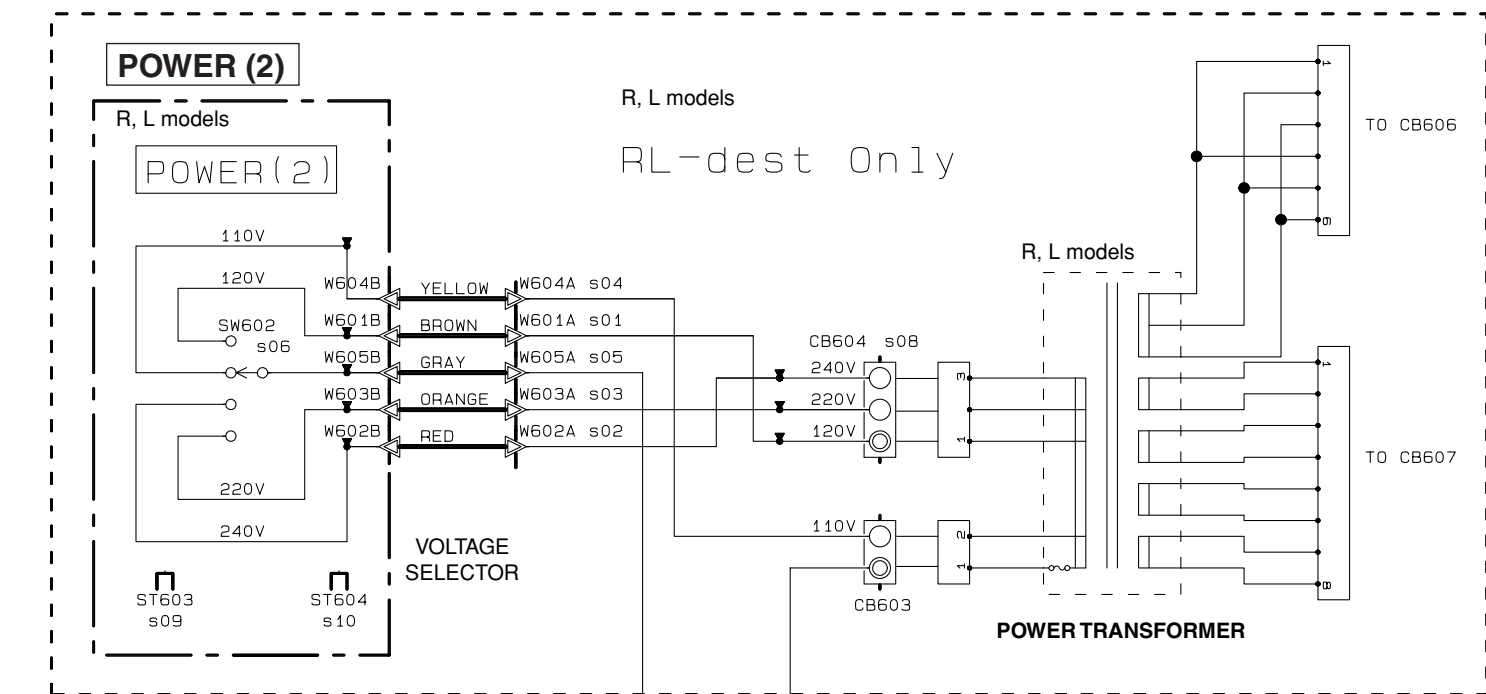

REMARKS	PARTS NAME
NO MARK	CARBON FILM RESISTOR (P=5)
□	CARBON FILM RESISTOR (P=10)
△	METAL OXIDE FILM RESISTOR
▲	METAL FILM RESISTOR
⊠	METAL PLATE RESISTOR
▤	FIRE PROOF CARBON FILM RESISTOR
□	CEMENT MOLDED RESISTOR
⊙	SEMI VARIABLE RESISTOR
■	CHIP RESISTOR

REMARKS	PARTS NAME
NO MARK	ELECTROLYTIC CAPACITOR
⊗	TANTALUM CAPACITOR
NO MARK	CERAMIC CAPACITOR
●	CERAMIC TUBULAR CAPACITOR
⊙	POLYESTER FILM CAPACITOR
○	POLYSTYRENE FILM CAPACITOR
⊖	MICA CAPACITOR
⊕	POLYPROPYLENE FILM CAPACITOR
⊗	SEMICONDUCTIVE CERAMIC CAPACITOR

NOTICE (model)
 (J)..... JAPAN
 (U)..... U.S.A
 (C)..... CANADA
 (R)..... GENERAL
 (T)..... CHINA
 (K)..... KOREA
 (A)..... AUSTRALIA
 (B)..... BRITISH
 (G)..... EUROPE
 (L)..... SINGAPORE
 (E)..... SOUTH EUROPE
 (V)..... TAIWAN
 (F)..... RUSSIAN

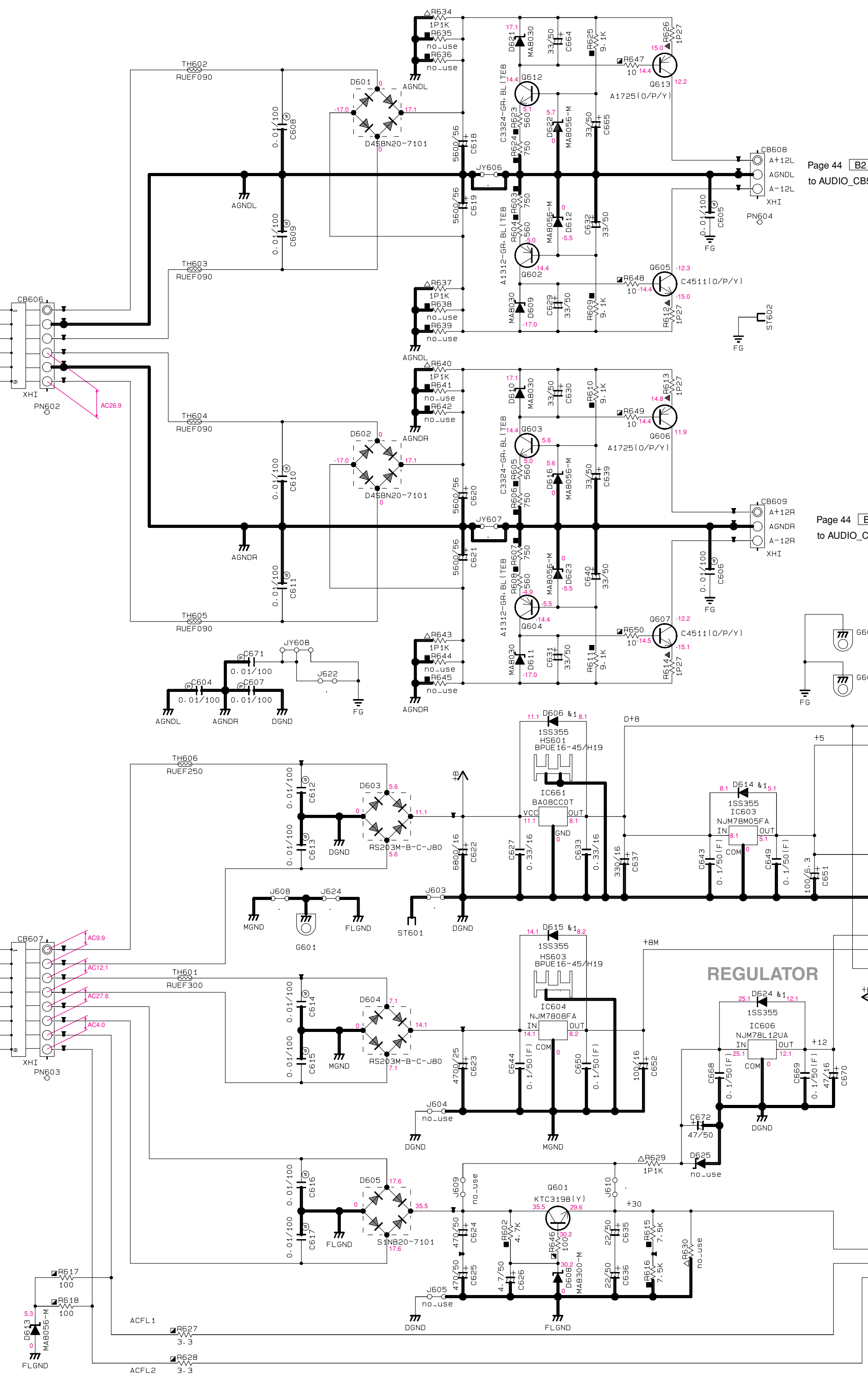
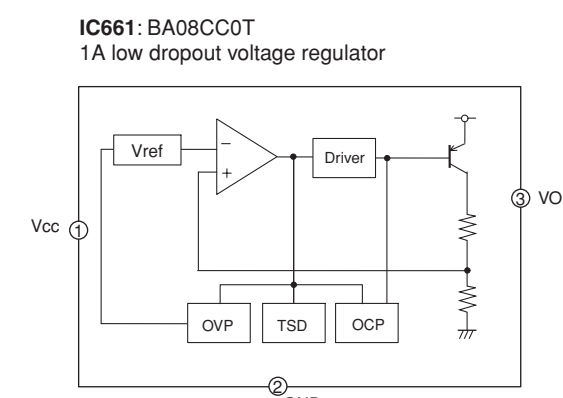
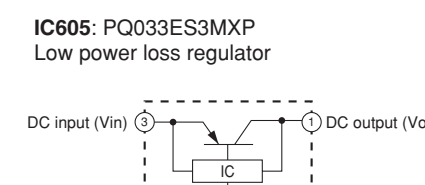
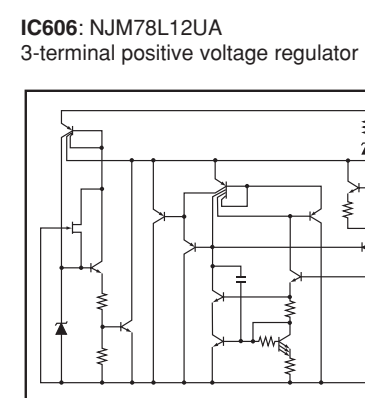
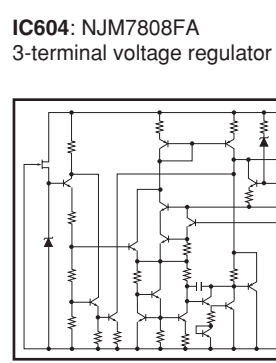
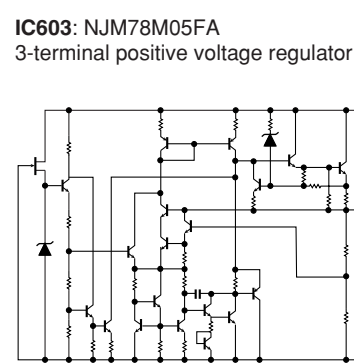

Destination Part List

sXX	LOC	J	UC	RL	TKA	BS
s1	W601	X	X	MH11016	X	X
s2	W602	X	X	MH12016	X	X
s3	W603	X	X	MH13016	X	X
s4	W604	X	X	MH14016	X	X
s5	W605	X	X	MH18016	X	X
s6	SW602	X	X	WHB1360 VSA-14-3	X	X
s8	CB604	X	X	V763780 WHS	X	X
s9	ST603	X	X	V404050	X	X
s10	ST604	X	X	V404050	X	X
s12	J601	VN50000	VN50000	X	VN50000	VN50000

Interchangeable Parts at Manufacture-Stage

Mark	Reference Parts Number	Parts Name
&1	D606, 614, 615, 617, 619, 620, 624	1SS355 MA2J1110GL KDS160-RTK/P
&2	IC605	PQ033ES3MXP PQ033ES1MXP

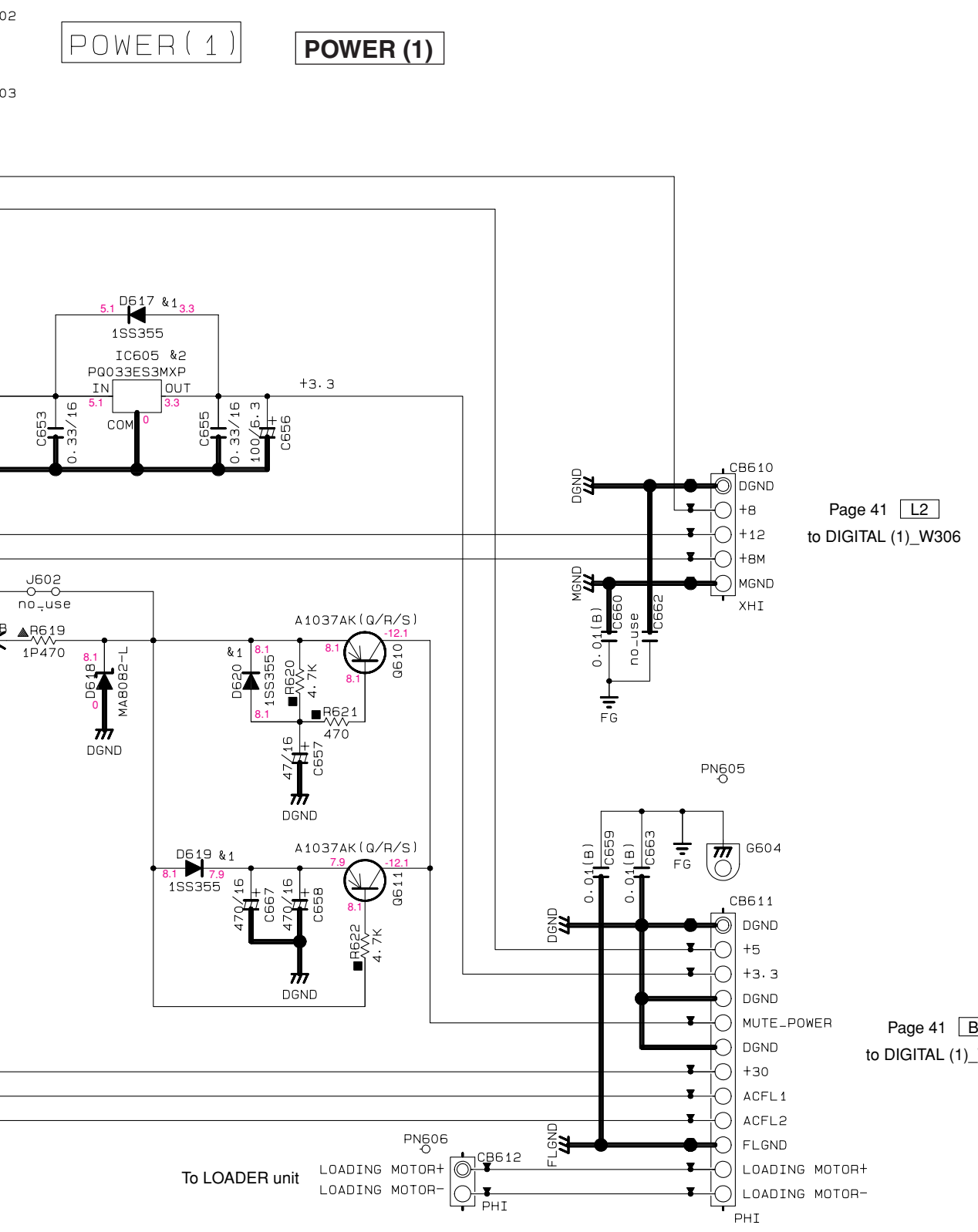

★ All voltages are measured with a 10MΩ/V DC electronic voltmeter.
 ★ Components having special characteristics are marked Δ and must be replaced with parts having specifications equal to those originally installed.
 ★ Schematic diagram is subject to change without notice.
 ● 電圧は、内部抵抗10MΩの電圧計で測定したものです。
 ● Δ 印のある部品は、安全性能部品を示しています。部品の交換が必要な場合、パーツリストに記載されている部品を使用してください。
 ● 本回路図は標準回路図です。改良のため予告なく変更することがございます。

■ REPLACEMENT PARTS LIST

• ELECTRICAL COMPONENT PARTS

WARNING

- Components having special characteristics are marked \triangle and must be replaced with parts having specifications equal to those originally installed.
- The chip resistor is not supplied as a replacement part.
 - * When a chip resistor is necessary, use the following part.
AAX60720: CHIP RESISTOR SAMPLE BOOK
- \triangle 印のある部分は、安全確保部品を示しています。部品の交換が必要な場合、パーツリストに記載されている部品を使用してください。
- チップ抵抗はサービス部品として供給しません。
 - ※ チップ抵抗が必要な場合は、下記の部品をご利用ください。
AAX60720: CHIP RESISTOR SAMPLE BOOK
- 部品価格ランクは、予告なく変更することがあります。

ABBREVIATIONS IN THIS LIST ARE AS FOLLOWS:

C.A.EL.CHP	: CHIP ALUMI.ELECTROLYTIC CAP	L.EMIT	: LIGHT EMITTING MODULE
C.CE	: CERAMIC CAP	LED.DSPLY	: LED DISPLAY
C.CE.ARRAY	: CERAMIC CAP ARRAY	LED.INFRD	: LED,INFRARED
C.CE.CHP	: CHIP CERAMIC CAP	MODUL.RF	: MODULATOR,RF
C.CE.ML	: MULTILAYER CERAMIC CAP	PHOT.CPL	: PHOTO COUPLER
C.CE.M.CHP	: CHIP MULTILAYER CERAMIC CAP	PHOT.INTR	: PHOTO INTERRUPTER
C.CE.SAFTY	: RECOGNIZED CERAMIC CAP	PHOT.RFLCT	: PHOTO REFLECTOR
C.CE.TUBLR	: CERAMIC TUBULAR CAP	PIN.TEST	: PIN,TEST POINT
C.CE.SMI	: SEMI CONDUCTIVE CERAMIC CAP	PLST.RIVET	: PLASTIC RIVET
C.EL	: ELECTROLYTIC CAP	R.ARRAY	: RESISTOR ARRAY
C.MICA	: MICA CAP	R.CAR.	: CARBON RESISTOR
C.ML.FLM	: MULTILAYER FILM CAP	R.CAR.CHP	: CHIP RESISTOR
C.MP	: METALLIZED PAPER CAP	R.CAR.FP	: FLAME PROOF CARBON RESISTOR
C.MYLAR	: MYLAR FILM CAP	R.FUS	: FUSABLE RESISTOR
C.MYLAR.ML	: MULTILAYER MYLAR FILM CAP	R.MTL.CHP	: CHIP METAL FILM RESISTOR
C.PAPER	: PAPER CAPACITOR	R.MTL.FLM	: METAL FILM RESISTOR
C.PLS	: POLYSTYRENE FILM CAP	R.MTL.OXD	: METAL OXIDE FILM RESISTOR
C.POL	: POLYESTER FILM CAP	R.MTL.PLAT	: METAL PLATE RESISTOR
C.POLY	: POLYETHYLENE FILM CAP	RSNR.CE	: CERAMIC RESONATOR
C.PP	: POLYPROPYLENE FILM CAP	RSNR.CRYS	: CRYSTAL RESONATOR
C.TNTL	: TANTALUM CAP	R.TW.CEM	: TWIN CEMENT FIXED RESISTOR
C.TNTL.CHP	: CHIP TANTALUM CAP	R.CEMENT	: CEMENT RESISTOR
C.TRIM	: TRIMMER CAP	SCR.BND.HD	: BIND HEAD B-TIGHT SCREW
CN	: CONNECTOR	SCR.BW.HD	: BW HEAD TAPPING SCREW
CN.BS.PIN	: CONNECTOR,BASE PIN	SCR.CUP	: CUP TIGHT SCREW
CN.CANNON	: CONNECTOR,CANNON	SCR.TERM	: SCREW TERMINAL
CN.DIN	: CONNECTOR,DIN	SCR.TR	: SCREW,TRANSISTOR
CN.FLAT	: CONNECTOR,FLAT CABLE	SUPRT.PCB	: SUPPORT,P.C.B.
CN.POST	: CONNECTOR,BASE POST	SURG.PRTCT	: SURGE PROTECTOR
COIL.MX.AM	: COIL,AM MIX	SW.TACT	: TACT SWITCH
COIL.AT.FM	: COIL,FM ANTENNA	SW.LEAF	: LEAF SWITCH
COIL.DT.FM	: COIL,FM DETECT	SW.LEVER	: LEVER SWITCH
COIL.MX.FM	: COIL,FM MIX	SW.MICRO	: MICRO SWITCH
COIL.OUTPT	: OUTPUT COIL	SW.PUSH	: PUSH SWITCH
DIOD.ARRAY	: DIODE ARRAY	SW.RT.ENC	: ROTARY ENCODER
DIODE.BRG	: DIODE BRIDGE	SW.RT.MTR	: ROTARY SWITCH WITH MOTOR
DIODE.CHP	: CHIP DIODE	SW.RT	: ROTARY SWITCH
DIODE.VAR	: VARACTOR DIODE	SW.SLIDE	: SLIDE SWITCH
DIOD.Z.CHP	: CHIP ZENER DIODE	TERM.SP	: SPEAKER TERMINAL
DIODE.ZENR	: ZENER DIODE	TERM.WRAP	: WRAPPING TERMINAL
DSCR.CE	: CERAMIC DISCRIMINATOR	THRMST.CHP	: CHIP THERMISTOR
FER.BEAD	: FERRITE BEADS	TR.CHP	: CHIP TRANSISTOR
FER.CORE	: FERRITE CORE	TR.DGT	: DIGITAL TRANSISTOR
FET.CHP	: CHIP FET	TR.DGT.CHP	: CHIP DIGITAL TRANSISTOR
FL.DSPLY	: FLUORESCENT DISPLAY	TRANS	: TRANSFORMER
FLTR.CE	: CERAMIC FILTER	TRANS.PULS	: PULSE TRANSFORMER
FLTR.COMB	: COMB FILTER MODULE	TRANS.PWR	: POWER TRANSFORMER ASS'Y
FLTR.LC.RF	: LC FILTER,EMI	TUNER.AM	: TUNER PACK,AM
GND.MTL	: GROUND PLATE	TUNER.FM	: TUNER PACK,FM
GND.TERM	: GROUND TERMINAL	TUNER.PK	: FRONT-ENDTUNER PACK
HOLDER.FUS	: FUSE HOLDER	VR	: ROTARY POTENTIOMETER
IC.PRTCT	: IC PROTECTOR	VR.MTR	: POTENTIOMETER WITH MOTOR
JUMPER.CN	: JUMPER CONNECTOR	VR.SW	: POTENTIOMETER WITH ROTARY SW
JUMPER.TST	: JUMPER,TEST POINT	VR.SLIDE	: SLIDE POTENTIOMETER
L.DTCT	: LIGHT DETECTING MODULE	VR.TRIM	: TRIMMER POTENTIOMETER

P.C.B. DIGITAL

Ref No.	Part No.	Description	Remarks	Markets	部 品 名	ランク
	WM129600	P. C. B.	DIGITAL		PCB DIGITAL	
CB301	WK469100	CN.FMN	FMN 29P TE		FMNコネクタ	
CB302	VB390100	CN.BS.PIN	5P		ベースピン	01
CB303	VQ047300	CN.BS.PIN	12P		FFCコネクタ	02
CB307	VQ047800	CN.BS.PIN	27P		FFCコネクタ	02
CB308	VP682300	CN.BS.PIN	8P		FFCコネクタ	01
CB800	VQ045000	CN.BS.PIN	20P		FFCコネクタ	01
CB802	VB858700	CN.BS.PIN	8P		ベースピン	01
CB901	VQ047800	CN.BS.PIN	27P		FFCコネクタ	02
CB902	VQ047500	CN.BS.PIN	20P		FFCコネクタ	01
CB903	V6217800	CN.BS.PIN	8P TE FMN		FFCコネクタ	01
C301-303	US064100	C.CE.CHP	0.01uF 50V B		チップセラコン	01
C304-305	US126100	C.CE.CHP	1uF 10V		チップセラコン	01
C306	US064100	C.CE.CHP	0.01uF 50V B		チップセラコン	01
C307	UR218100	C.EL	100uF 6.3V		ケミコン	
C308	US061330	C.CE.CHP	33pF 50V B		チップセラコン	01
C309-310	US064100	C.CE.CHP	0.01uF 50V B		チップセラコン	01
C311-313	US035100	C.CE.CHP	0.1uF 16V B		チップセラコン	01
C314	UR238100	C.EL	100uF 16V		ケミコン	
C315-316	US035100	C.CE.CHP	0.1uF 16V B		チップセラコン	01
C317	US064100	C.CE.CHP	0.01uF 50V B		チップセラコン	01
C318	UR238100	C.EL	100uF 16V		ケミコン	
C319	US035100	C.CE.CHP	0.1uF 16V B		チップセラコン	01
C320-321	US064100	C.CE.CHP	0.01uF 50V B		チップセラコン	01
C322-325	US061330	C.CE.CHP	33pF 50V B		チップセラコン	01
C326	UR237330	C.EL	33uF 16V		ケミコン	
C327	UR237470	C.EL	47uF 16V		ケミコン	01
C328	US062330	C.CE.CHP	330pF 50V B		チップセラコン	01
C329	US064100	C.CE.CHP	0.01uF 50V B		チップセラコン	01
C330	UR237470	C.EL	47uF 16V		ケミコン	01
C331	WN488900	C.EL	1000uF 16V		ケミコン FW	
C332-334	US064100	C.CE.CHP	0.01uF 50V B		チップセラコン	01
C336	US064100	C.CE.CHP	0.01uF 50V B		チップセラコン	01
C337	US062330	C.CE.CHP	330pF 50V B		チップセラコン	01
C338-344	US064100	C.CE.CHP	0.01uF 50V B		チップセラコン	01
C345-347	US035100	C.CE.CHP	0.1uF 16V B		チップセラコン	01
C348-349	UR218100	C.EL	100uF 6.3V		ケミコン	
C350	UR258100	C.EL	100uF 35V		ケミコン	
C351-352	US064100	C.CE.CHP	0.01uF 50V B		チップセラコン	01
C353	US064150	C.CE.CHP	0.015uF 50V B		チップセラコン	01
C354	US064100	C.CE.CHP	0.01uF 50V B		チップセラコン	01
C355	US064150	C.CE.CHP	0.015uF 50V B		チップセラコン	01
C356-357	US064100	C.CE.CHP	0.01uF 50V B		チップセラコン	01
C358-359	US063100	C.CE.CHP	1000pF 50V B		チップセラコン	01
C360	US135100	C.CE.CHP	0.1uF 16V		チップセラコン	01
C361	US064100	C.CE.CHP	0.01uF 50V B		チップセラコン	01
C362	UR258100	C.EL	100uF 35V		ケミコン	
C363-364	US064150	C.CE.CHP	0.015uF 50V B		チップセラコン	01
C800	US135100	C.CE.CHP	0.1uF 16V		チップセラコン	01
C801-803	US062100	C.CE.CHP	100pF 50V B		チップセラコン	01
C804-805	US064100	C.CE.CHP	0.01uF 50V B		チップセラコン	01
C806	US065100	C.CE.CHP	0.1uF 50V B		チップセラコン	01
C809	US135100	C.CE.CHP	0.1uF 16V		チップセラコン	01
C810	US064100	C.CE.CHP	0.01uF 50V B		チップセラコン	01
C811-815	US135100	C.CE.CHP	0.1uF 16V		チップセラコン	01

* New Parts * 新規部品

P.C.B. DIGITAL and P.C.B. AUDIO

Ref No.	Part No.	Description	Remarks	Markets	部 品 名	ランク
C816-817	WG780700	C. EL	47uF 16V		ケミコン	
C818-820	US064100	C. CE. CHP	0.01uF 50V B		チップセラコン	01
C830	US126100	C. CE. CHP	1uF 10V		チップセラコン	01
C831	WG888300	C. CE. M. CHP	10uF 6.3V		チップ積層セラコン	01
C832	US065100	C. CE. CHP	0.1uF 50V B		チップセラコン	01
D301-302	VV220700	DIODE. SHOT	RB501V-40		ショットキーダイオード	01
D303	VT332900	DIODE	1SS355		ダイオード	01
D304	VV220700	DIODE. SHOT	RB501V-40		ショットキーダイオード	01
D305	VT332900	DIODE	1SS355		ダイオード	01
D307	VT332900	DIODE	1SS355		ダイオード	01
D309-310	VU992300	DIODE. ZENR	MA8047-H 4.9V		ツェナーダイオード	01
D801-803	WA467800	LED	SEL6910A-CD		L E D	01
D804	VU993000	DIODE. ZENR	MA8056-M 5.6V		ツェナーダイオード	01
IC301	X3904A00	IC	TS7ST00F NAND		ロジックIC	01
IC302	X9278A00	IC. CPU	M30302FAPFP CPU	boot only	C P U / 周辺 I C	
IC303-304	XF494A00	IC	LB1641		I C	03
IC305	X5868A00	IC	BD4829G RESET IC		I C	
IC306	XZ012A00	IC	TC74HCT08AF(EL)		ロジックIC	01
IC307	XN567A00	IC	TC7WU04F INV		I C	01
IC308	XZ012A00	IC	TC74HCT08AF(EL)		ロジックIC	01
IC802	X2656A00	IC	TC7SH08F AND		ロジックIC	01
PJ301	V2283400	JACK. PIN	1P		ピンジャック	04
Q301	VV556400	TR	2SC2412K Q, R, S		トランジスタ	01
Q302	VV556500	TR	2SA1037K Q, R, S		トランジスタ	01
Q800	VV556400	TR	2SC2412K Q, R, S		トランジスタ	01
Q801-803	VV655400	TR. DGT	DTC114EKA		デジタルトランジスタ	01
Q804	VV556400	TR	2SC2412K Q, R, S		トランジスタ	01
R333	HV753220	R. CAR. FP	2.2Ω 1/4W		不燃化カーボン抵抗	01
R362	HV753220	R. CAR. FP	2.2Ω 1/4W		不燃化カーボン抵抗	01
ST301-302	WG095100	SCR. TERM	M3		スクリューターミナル	01
SW800-807	WD483100	SW. TACT	SKRGAAD010		タクト SW	01
U301	WH536900	CN. PHOTO. T	1P GP1FAV51TK0F		光ファイバー送信器	04
U800	WH981800	L. DTCT	GP1UE261RKVF		リモコン受光ユニット	02
V800	WK835500	FL. DSPLY	13-ST-81GINK		蛍光表示管	
XL301	V8222200	RSNR. CE	10MHz CSTLS10M0		セラミック振動子	01
	WM164600	SHEET			シートFL	
	V6203300	SPACER. FL			スペーサーFL	01
	WM128100	P. C. B.	AUDIO		P C B A U D I O	
	WM128200	P. C. B.	AUDIO	J	P C B A U D I O	
	WM128300	P. C. B.	AUDIO	UCRTKAL BG	P C B A U D I O	
CB1	V6313300	CN. BS. PIN	17P TE		FMNコネクター	
CB2	VQ047300	CN. BS. PIN	12P		F F C コネクター	02
CB5-6	VL844700	CN. BS. PIN	3P		ベース付ポスト	01
C1-2	US064100	C. CE. CHP	0.01uF 50V B		チップセラコン	01
C3	WE102700	C. PP	6800pF 100V		P P コン	01
C4	WE102900	C. PP	0.01uF 100V		P P コン	
C5-6	WE102200	C. PP	2700pF 100V		P P コン	01
C7	UU268470	C. EL	470uF 50V		ケミコン FW	
C8-10	US064100	C. CE. CHP	0.01uF 50V B		チップセラコン	01
C11-13	UU238100	C. EL	100uF 16V		ケミコン	01
C14-17	US062100	C. CE. CHP	100pF 50V B		チップセラコン	01
C18-21	WN165300	C. PP	0.01uF 100V		P P コン	

*
*
*

* New Parts * 新規部品

P.C.B. AUDIO

Ref No.	Part No.	Description	Remarks	Markets	部 品 名	ランク
C24-27	WN165300	C.PP	0.01uF 100V		P Pコン	
C30-31	UU237470	C.EL	47uF 16V		ケミコン FW	
C33	UU237470	C.EL	47uF 16V		ケミコン FW	
C35	UU237470	C.EL	47uF 16V		ケミコン FW	
C37-40	UU237470	C.EL	47uF 16V		ケミコン FW	
C43	UU237100	C.EL	10uF 16V		ケミコン FW	
C46-47	UU268470	C.EL	470uF 50V		ケミコン FW	
C48-49	WN165300	C.PP	0.01uF 100V		P Pコン	
C50-51	UU238100	C.EL	100uF 16V		ケミコン	01
C52-53	WN165300	C.PP	0.01uF 100V		P Pコン	
C54	UU238100	C.EL	100uF 16V		ケミコン	01
C55	WE102900	C.PP	0.01uF 100V		P Pコン	
C56	UU238100	C.EL	100uF 16V		ケミコン	01
C57	WE102900	C.PP	0.01uF 100V		P Pコン	
C64-65	UU238100	C.EL	100uF 16V		ケミコン	01
C66-68	WE102700	C.PP	6800pF 100V		P Pコン	01
C69-71	WE102900	C.PP	0.01uF 100V		P Pコン	
C72-77	WE102200	C.PP	2700pF 100V		P Pコン	01
C78-82	WE101700	C.PP	1000pF 100V		P Pコン	
C85	WE101700	C.PP	1000pF 100V		P Pコン	
C88	WE100900	C.PP	220pF 630V		P Pコン	02
C91	WE100900	C.PP	220pF 630V		P Pコン	02
C100	UU268470	C.EL	470uF 50V		ケミコン FW	
C105	WE101700	C.PP	1000pF 100V		P Pコン	
C108	WE101700	C.PP	1000pF 100V		P Pコン	
C111-118	WE101500	C.PP	680pF 100V J		P Pコン	01
C119-126	UU237470	C.EL	47uF 16V		ケミコン FW	
C127-134	WN165300	C.PP	0.01uF 100V		P Pコン	
C135-136	UU237470	C.EL	47uF 16V		ケミコン FW	
C137	UU238100	C.EL	100uF 16V		ケミコン	
C139-140	WE102900	C.PP	0.01uF 100V		P Pコン	
C141-142	UU237470	C.EL	47uF 16V		ケミコン FW	
C144	UU238100	C.EL	100uF 16V		ケミコン	
C145-150	WE102900	C.PP	0.01uF 100V		P Pコン	
C151-154	UU268470	C.EL	470uF 50V		ケミコン FW	
C155-156	US064100	C.CE. CHP	0.01uF 50V B		チップセラコン	01
C157-160	US065100	C.CE. CHP	0.1uF 50V B		チップセラコン	01
C161-162	UU238100	C.EL	100uF 16V		ケミコン	
C163	UU237100	C.EL	10uF 16V		ケミコン FW	
C164-165	WE102900	C.PP	0.01uF 100V		P Pコン	
C166-169	WE102500	C.PP	4700pF 100V		P Pコン	01
C170-171	US064100	C.CE. CHP	0.01uF 50V B		チップセラコン	01
C174-175	US064100	C.CE. CHP	0.01uF 50V B		チップセラコン	01
D1-4	VU996100	DIODE. ZENR	MA8120-L 11.7V		ツェナーダイオード	01
D5-6	VU993400	DIODE. ZENR	MA8062-M 6.2V		ツェナーダイオード	01
* IC1	X9018A00	IC	PCM1796DBR		D/Aコンバーター	
* IC3	X9430A00	IC	PQ033ES3MXP		電源IC	
* IC4	X9018A00	IC	PCM1796DBR		D/Aコンバーター	
IC10	XT475B00	IC	TC74VHC157F EL, K, F		ロジックIC	
IC11	X9430A00	IC	PQ033ES3MXP		電源IC	
IC12-13	XT014A00	IC	TC74VHC08F		IC	01
IC14	X5482A00	IC	NE5532DR OP AMP		アンプIC	01
* IC15	YA089A00	IC	LME49723MA		アンプIC	01
IC16	X5482A00	IC	NE5532DR OP AMP		アンプIC	01
* IC17	YA089A00	IC	LME49723MA		アンプIC	01

* New Parts * 新規部品

P.C.B. AUDIO

Ref No.	Part No.	Description	Remarks	Markets	部 品 名	ランク
IC19-22	X5482A00	IC	NE5532DR OP AMP		アンプ IC	01
JY6	WK849100	BUS.BAR. 3P	3P		バスバー 3P	
PJ1	WK897800	JACK. PIN	JACK T6782-AAAC		ピンジャック	
PJ4	WK897800	JACK. PIN	JACK T6782-AAAC		ピンジャック	
PN3	V9637500	PIN	L=70 #18		スタイルピン	
Q1	iC287820	TR	2SC2878 A,B		トランジスタ	01
Q2	VV655400	TR. DGT	DTC114EKA		デジタルトランジスタ	01
Q3	VV655000	TR. DGT	DTA114EKA		デジタルトランジスタ	01
Q6	iC287820	TR	2SC2878 A,B		トランジスタ	01
Q9	VZ725900	TR	2SD1938F S,T		トランジスタ	01
Q12	VZ725900	TR	2SD1938F S,T		トランジスタ	01
Q15	VZ725900	TR	2SD1938F S,T		トランジスタ	01
Q18	VZ725900	TR	2SD1938F S,T		トランジスタ	01
Q23-24	WG408800	TR	2SA2168 S,T		トランジスタ	03
Q25-26	WG408900	TR	2SC5291 S,T		トランジスタ	03
Q27-28	WF691400	TR	2SD2014		トランジスタ	03
Q29-30	VR043100	FET	2SK208 Y		チップ F E T	01
R2-3	HL005330	R. MTL. OXD	330Ω 1/2W		酸化金属被膜抵抗	01
R4	HL005680	R. MTL. OXD	680Ω 1/2W		酸化金属被膜抵抗	
R5	HL005470	R. MTL. OXD	470Ω 1/2W		酸化金属被膜抵抗	
R6	HL005270	R. MTL. OXD	270Ω 1/2W		酸化金属被膜抵抗	
R7	HL005330	R. MTL. OXD	330Ω 1/2W		酸化金属被膜抵抗	01
R8	HL005680	R. MTL. OXD	680Ω 1/2W		酸化金属被膜抵抗	
R9	HL005470	R. MTL. OXD	470Ω 1/2W		酸化金属被膜抵抗	
R10	HL005270	R. MTL. OXD	270Ω 1/2W		酸化金属被膜抵抗	
R13	HL005330	R. MTL. OXD	330Ω 1/2W		酸化金属被膜抵抗	01
R19-20	HL005330	R. MTL. OXD	330Ω 1/2W		酸化金属被膜抵抗	01
R33-34	HV753470	R. CAR. FP	4.7Ω 1/4W		不燃化カーボン抵抗	01
R35-36	HV753100	R. CAR. FP	1Ω 1/4W		不燃化カーボン抵抗	01
R42-43	HL005330	R. MTL. OXD	330Ω 1/2W		酸化金属被膜抵抗	01
R44-49	HL005680	R. MTL. OXD	680Ω 1/2W		酸化金属被膜抵抗	
R50-52	HL005270	R. MTL. OXD	270Ω 1/2W		酸化金属被膜抵抗	
R53-58	HL005470	R. MTL. OXD	470Ω 1/2W		酸化金属被膜抵抗	
R59-61	HL005270	R. MTL. OXD	270Ω 1/2W		酸化金属被膜抵抗	
R62-69	HL006100	R. MTL. OXD	1KΩ 1/2W		酸化金属被膜抵抗	
R70	HL005820	R. MTL. OXD	820Ω 1/2W		酸化金属被膜抵抗	
R74	HL005820	R. MTL. OXD	820Ω 1/2W		酸化金属被膜抵抗	
R76	HL007220	R. MTL. OXD	22KΩ 1/2W		酸化金属被膜抵抗	
R81	HL007220	R. MTL. OXD	22KΩ 1/2W		酸化金属被膜抵抗	
R88	HL006560	R. MTL. OXD	5.6KΩ 1/2W		酸化金属被膜抵抗	
R91	HL006560	R. MTL. OXD	5.6KΩ 1/2W		酸化金属被膜抵抗	
R94	HL006220	R. MTL. OXD	2.2KΩ 1/2W		酸化金属被膜抵抗	
R97	HL006220	R. MTL. OXD	2.2KΩ 1/2W		酸化金属被膜抵抗	
R100	V8072500	R. MTL. OXD	22KΩ 1W		酸化金属被膜抵抗	
R103	V8072500	R. MTL. OXD	22KΩ 1W		酸化金属被膜抵抗	
R106	WA621700	R. MTL. FLM	270Ω 1W		金属被膜抵抗	
R116	WA621700	R. MTL. FLM	270Ω 1W		金属被膜抵抗	
R118	WA621700	R. MTL. FLM	270Ω 1W		金属被膜抵抗	
R126	WA621700	R. MTL. FLM	270Ω 1W		金属被膜抵抗	
R130	V8070900	R. MTL. FLM	100Ω 1W		金属被膜抵抗	01
R135	V8070900	R. MTL. FLM	100Ω 1W		金属被膜抵抗	01
R141-148	V8071700	R. MTL. OXD	1.5KΩ 1W		酸化金属被膜抵抗	01
R149-150	WN448800	R. MTL. OXD	10KΩ 1W		酸化金属被膜抵抗	
R158-159	HV753470	R. CAR. FP	4.7Ω 1/4W		不燃化カーボン抵抗	01
R160-161	HV755100	R. CAR. FP	100Ω 1/4W		不燃化カーボン抵抗	01

* New Parts * 新規部品

P.C.B. AUDIO and P.C.B. POWER

Ref No.	Part No.	Description	Remarks	Markets	部 品 名	ランク
R162-165	HL006100	R. MTL. OXD	1KΩ 1/2W			
ST1-2	WG095100	SCR. TERM	M3		J	酸化金属被膜抵抗
ST1-2	V4040500	SCR. TERM	M3		UCRTKABGL	スクリューターミナル
						スクリューターミナル
	WM129100	P. C. B.	POWER		J	P C B パワー
	WM129200	P. C. B.	POWER		UC	P C B パワー
	WM129300	P. C. B.	POWER		RL	P C B パワー
	WM129400	P. C. B.	POWER		TKA	P C B パワー
	WM129500	P. C. B.	POWER		BG	P C B パワー
CB601	VG879900	CN. BS. PIN	2P			ベースピン
CB603	VG879900	CN. BS. PIN	2P			ベースピン
CB604	VT637800	CN. BS. PIN	3P		RL	ベース付ポスト
CB606	VL845000	CN. BS. PIN	6P			ベース付ポスト
CB607	VL845200	CN. BS. PIN	8P			ベース付ポスト
CB608-609	VL844700	CN. BS. PIN	3P			ベース付ポスト
CB610	VL844900	CN. BS. PIN	5P			ベース付ポスト
CB611	VB390800	CN. BS. PIN	12P			コネクタベースポスト
CB612	VB389800	CN. BS. PIN	2P			ベースピン
CB613-614	WN103000	CL. IP. FUSE	TP00351-31			ヒューズクリップ
CB615	VG879900	CN. BS. PIN	2P			ベースピン
C602-603	V6185300	C. CE. SAFTY	0.01uF 275V			規格認定コンデンサ
C604	WN165300	C. PP	0.01uF 100V			P Pコン
C605-606	WN165300	C. PP	0.01uF 100V			P Pコン
C607	WN165300	C. PP	0.01uF 100V			P Pコン
C608-611	WN165300	C. PP	0.01uF 100V			P Pコン
C612-617	WN165300	C. PP	0.01uF 100V			P Pコン
C618-621	WG399700	C. EL	5600uF 56V			ケミコン
C622	UR239680	C. EL	6800uF 16V			ケミコン
C623	UR249470	C. EL	4700uF 25V			ケミコン
C624-625	UR268470	C. EL	470uF 50V			ケミコン
C626	UR266470	C. EL	4.7uF 50V			ケミコン
C627	US135330	C. CE. CHP	0.33uF 16V			チップセラコン
C629-632	UU267330	C. EL	33uF 50V			ケミコン FW
C633	US135330	C. CE. CHP	0.33uF 16V			チップセラコン
C635-636	UR267220	C. EL	22uF 50V			ケミコン
C637	WM553800	C. EL	330uF 16V			ケミコン
C639-640	UU267330	C. EL	33uF 50V			ケミコン FW
C643-644	US065100	C. CE. CHP	0.1uF 50V B			チップセラコン
C649-650	US065100	C. CE. CHP	0.1uF 50V B			チップセラコン
C651	UR218100	C. EL	100uF 6.3V			ケミコン
C652	WG226200	C. EL	100uF 16V			ケミコン
C653	US135330	C. CE. CHP	0.33uF 16V			チップセラコン
C655	US135330	C. CE. CHP	0.33uF 16V			チップセラコン
C656	UR218100	C. EL	100uF 6.3V			ケミコン
C657	UR237470	C. EL	47uF 16V			ケミコン
C658	UR238470	C. EL	470uF 16V			ケミコン
C659-660	US064100	C. CE. CHP	0.01uF 50V B			チップセラコン
C663	US064100	C. CE. CHP	0.01uF 50V B			チップセラコン
C664-665	UU267330	C. EL	33uF 50V			ケミコン FW
C666	V6185300	C. CE. SAFTY	0.01uF 275V			規格認定コンデンサ
C667	UR238470	C. EL	470uF 16V			ケミコン
C668-669	US065100	C. CE. CHP	0.1uF 50V B			チップセラコン
C670	UR237470	C. EL	47uF 16V			ケミコン

* New Parts * 新規部品

P.C.B. POWER

Carbon Resistors

Ref No.	Part No.	Description	Remarks	Markets	部 品 名	ランク
C671	WN165300	C.PP	0.01uF 100V		PPコン	
C672	UR267470	C.EL	47uF 50V		ケミコン	01
D601-602	WK870400	DIODE.BRG	D4SBN20-7101 4A		ダイオードブリッジ	
D603-604	WH487300	DIODE.BRG	RS203M 2.0A 200V		ダイオードブリッジ	02
D605	VR253700	DIODE.BRG	S1NB20 1A 200V		ダイオードブリッジ	02
D606	VT332900	DIODE	1SS355		ダイオード	01
D608	VU999900	DIODE.ZENR	MA8300-M 30V		ツェナーダイオード	01
D609-611	VU990400	DIODE.ZENR	MA8030 3V		ツェナーダイオード	
D612-613	VU993000	DIODE.ZENR	MA8056-M 5.6V		ツェナーダイオード	01
D614-615	VT332900	DIODE	1SS355		ダイオード	01
D616	VU993000	DIODE.ZENR	MA8056-M 5.6V		ツェナーダイオード	01
D617	VT332900	DIODE	1SS355		ダイオード	01
D618	VU994500	DIODE.ZENR	MA8082-L 7.9V		ツェナーダイオード	
D619-620	VT332900	DIODE	1SS355		ダイオード	01
D621	VU990400	DIODE.ZENR	MA8030 3V		ツェナーダイオード	
D622-623	VU993000	DIODE.ZENR	MA8056-M 5.6V		ツェナーダイオード	01
D624	VT332900	DIODE	1SS355		ダイオード	01
F601	KB000680	FUSE	1.25A 250V		ヒューズ	02
IC603	XJ604A00	IC	NJM78M05FA		IC	02
IC604	XD801A00	IC	NJM7808FA 8V		電源IC	02
IC605	X9430A00	IC	P0033ES3MXP		電源IC	
IC606	X3532A00	IC	NJM78L12UA(Te1) 12		電源IC フラット	01
IC661	X9381A00	IC	BA08CCOT 8V		電源IC	
PN601-606	V8637500	PIN	L=50 #18		スタイルピン	
Q601	WB228800	TR	KTC3198 Y AT		トランジスタ	
Q602	V7421800	TR	2SA1312-GR, BL		トランジスタ	01
Q603	V7421700	TR. CHP	2SC3324-GR, BL		チップトランジスタ	01
Q604	V7421800	TR	2SA1312-GR, BL		トランジスタ	01
Q605	WM280600	TR	2SC4511 O,P,Y		トランジスタ 2SC	
Q606	WM280500	TR	SCA1725 O,P,Y		トランジスタ 2SA	
Q607	WM280600	TR	2SC4511 O,P,Y		トランジスタ 2SC	
Q610-611	VV556500	TR	2SA1037K Q,R,S		トランジスタ	01
Q612	V7421700	TR. CHP	2SC3324-GR, BL		チップトランジスタ	01
Q613	WM280500	TR	SCA1725 O,P,Y		トランジスタ 2SA	
* R612-614	WA621100	R.MTL.FLM	27Ω 1W		金属被膜抵抗	
R617-618	HV755100	R.CAR.FP	100Ω 1/4W		不燃化カーボン抵抗	01
R619	V8071300	R.MTL.FLM	470Ω 1W		金属被膜抵抗	
* R626	WA621100	R.MTL.FLM	27Ω 1W		金属被膜抵抗	
R627-628	HV753330	R.CAR.FP	3.3Ω 1/4W		不燃化カーボン抵抗	01
R629	V8071600	R.MTL.OXD	1KΩ 1W		金属被膜抵抗	
R634	V8071600	R.MTL.OXD	1KΩ 1W		金属被膜抵抗	
R637	V8071600	R.MTL.OXD	1KΩ 1W		金属被膜抵抗	
R640	V8071600	R.MTL.OXD	1KΩ 1W		金属被膜抵抗	
R643	V8071600	R.MTL.OXD	1KΩ 1W		金属被膜抵抗	
R646	HV755100	R.CAR.FP	100Ω 1/4W		不燃化カーボン抵抗	01
R647-650	HV754100	R.CAR.FP	10Ω 1/4W		不燃化カーボン抵抗	01
ST601-602	WG095100	SCR. TERM	M3	J	スクリューターミナル	
ST601-602	V4040500	SCR. TERM	M3	UCRTKABGL	スクリューターミナル	01
ST603-604	V4040500	SCR. TERM	M3	RL	スクリュー/ターミナル	01
SW602	WH813600	VOLT. SELCT	VSA-14-3		電圧切替器	
TE601	WB893300	AC INLET	R-30190	RL	ACインレット 2P	03
TH601	VV458100	SW.POLY	RUE300 3.A 30V		ポリスイッチ	03
TH602-605	VV457600	SW.POLY	RUE090 0.90A 30V		ポリスイッチ	02
TH606	VV458000	SW.POLY	RUE250 2.50A 30V		ポリスイッチ	03
	WE983600	SCR. BND. HD	3x8 MFZN2B3		バインド小ネジ	01

* New Parts * 新規部品

Value	1/4W Type Part No.	1/6W Type Part No.	Value	1/4W Type Part No.	1/6W Type Part No.
1.0 Ω	HJ35 3100	HF85 3100	10 kΩ	HF45 7100	HF45 7100
1.8 Ω	HJ35 3180	*	11 kΩ	HF45 7110	HF45 7110
2.2 Ω	HJ35 3220	HF85 3220	12 kΩ	HJ35 7120	HF85 7120
3.3 Ω	HJ35 3330	HF85 3330	13 kΩ	HF45 7130	HF45 7130
4.7 Ω	HJ35 3470	HF85 3470	15 kΩ	HF45 7150	HF45 7150
5.6 Ω	HJ35 3560	HF85 3560	18 kΩ	HF45 7180	HF45 7180
10 Ω	HF45 4100	HF45 4100	22 kΩ	HF45 7220	HF45 7220
15 Ω	HJ35 4150	HF85 4150	24 kΩ	HF45 7240	HF45 7240
22 Ω	HF45 4220	HF45 4220	27 kΩ	HJ35 7270	HF85 7270
27 Ω	HJ35 4270	HF85 4270	30 kΩ	HF45 7300	HF45 7300
33 Ω	HF45 4330	HF45 4330	33 kΩ	HF45 7330	HF45 7330
39 Ω	HJ35 4470	HF85 4390	36 kΩ	HF45 7360	HF45 7360
47 Ω	HF45 4470	HF45 4470	39 kΩ	HF45 7390	HF45 7390
56 Ω	HF45 4560	HF45 4560	47 kΩ	HF45 7470	HF45 7470
68 Ω	HF45 4680	HF45 4680	51 kΩ	HF45 7510	HF45 7510
75 Ω	HF45 4750	HF45 4750	56 kΩ	HF45 7560	HF45 7560
82 Ω	HF45 4820	HF45 4820	62 kΩ	HF45 7620	HF45 7620
91 Ω	HF45 4910	HF45 4910	68 kΩ	HF45 7680	HF45 7680
100 Ω	HF45 5100	HF45 5100	82 kΩ	HF45 7820	HF45 7820
110 Ω	HJ35 5110	HF85 5110	91 kΩ	HF45 7910	HF45 7910
120 Ω	HF45 5120	HF45 5120	100 kΩ	HF45 8100	HF45 8100
150 Ω	HF45 5150	HF45 5150	110 kΩ	HF45 8110	HF45 8110
160 Ω	HJ35 5160	*	120 kΩ	HF45 8120	HF45 8120
180 Ω	HF45 5180	HF45 5180	150 kΩ	HF45 8150	HF45 8150
200 Ω	HF45 5200	HF45 5200	180 kΩ	HF45 8180	HF45 8180
220 Ω	HF45 5220	HF45 5220	220 kΩ	HJ35 8220	HF85 8220
270 Ω	HF45 5270	HF45 5270	270 kΩ	HF45 8270	HF45 8270
330 Ω	HF45 5330	HF45 5330	300 kΩ	HF45 8300	HF45 8300
390 Ω	HF45 5390	HF45 5390	330 kΩ	HF45 8330	HF45 8330
430 Ω	HF45 5430	HF45 5430	390 kΩ	HJ35 8390	HF85 8390
470 Ω	HF45 5470	HF45 5470	470 kΩ	HF45 8470	HF45 8470
510 Ω	HF45 5510	HF45 5510	560 kΩ	HJ35 8560	HF85 8560
560 Ω	HF45 5560	HF45 5560	680 kΩ	HJ35 8680	HF85 8680
680 Ω	HF45 5680	HF45 5680	820 kΩ	HJ35 8820	HF85 8820
820 Ω	HF45 5820	HF45 5820	1.0 MΩ	HF45 9100	HF45 9100
910 Ω	HF45 5910	HF45 5910	1.2 MΩ	HJ35 9120	*
1.0 kΩ	HF45 6100	HF45 6100	1.5 MΩ	HJ35 9150	HF85 9150
1.2 kΩ	HF45 6120	HF45 6120	1.8 MΩ	HJ35 9180	HF85 9180
1.5 kΩ	HF45 6150	HF45 6150	2.2 MΩ	HJ35 9220	HF85 9220
1.8 kΩ	HF45 6180	HF45 6180	3.3 MΩ	HJ35 9330	HF85 9330
2.0 kΩ	HJ35 6200	HF85 6200	3.9 MΩ	HJ35 9390	*
2.2 kΩ	HF45 6220	HF45 6220	4.7 MΩ	HJ35 9470	HF85 9470
2.4 kΩ	HJ35 6240	HF85 6240			
2.7 kΩ	HF45 6270	HF45 6270			
3.0 kΩ	HF45 6300	HF45 6300			
3.3 kΩ	HF45 6330	HF45 6330			
3.6 kΩ	HJ35 6360	HF85 6360			
3.9 kΩ	HF45 6390	HF45 6390			
4.7 kΩ	HF45 6470	HF45 6470			
5.1 kΩ	HF45 6510	HF45 6510			
5.6 kΩ	HF45 6560	HF45 6560			
6.8 kΩ	HF45 6680	HF45 6680			
8.2 kΩ	HF45 6820	HF45 6820			
9.1 kΩ	HF45 6910	HF45 6910			

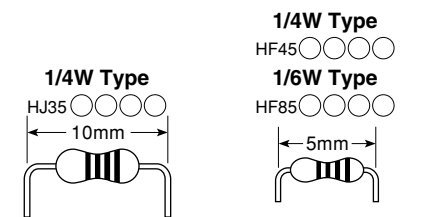

* : Not available

• OVERALL ASS'Y

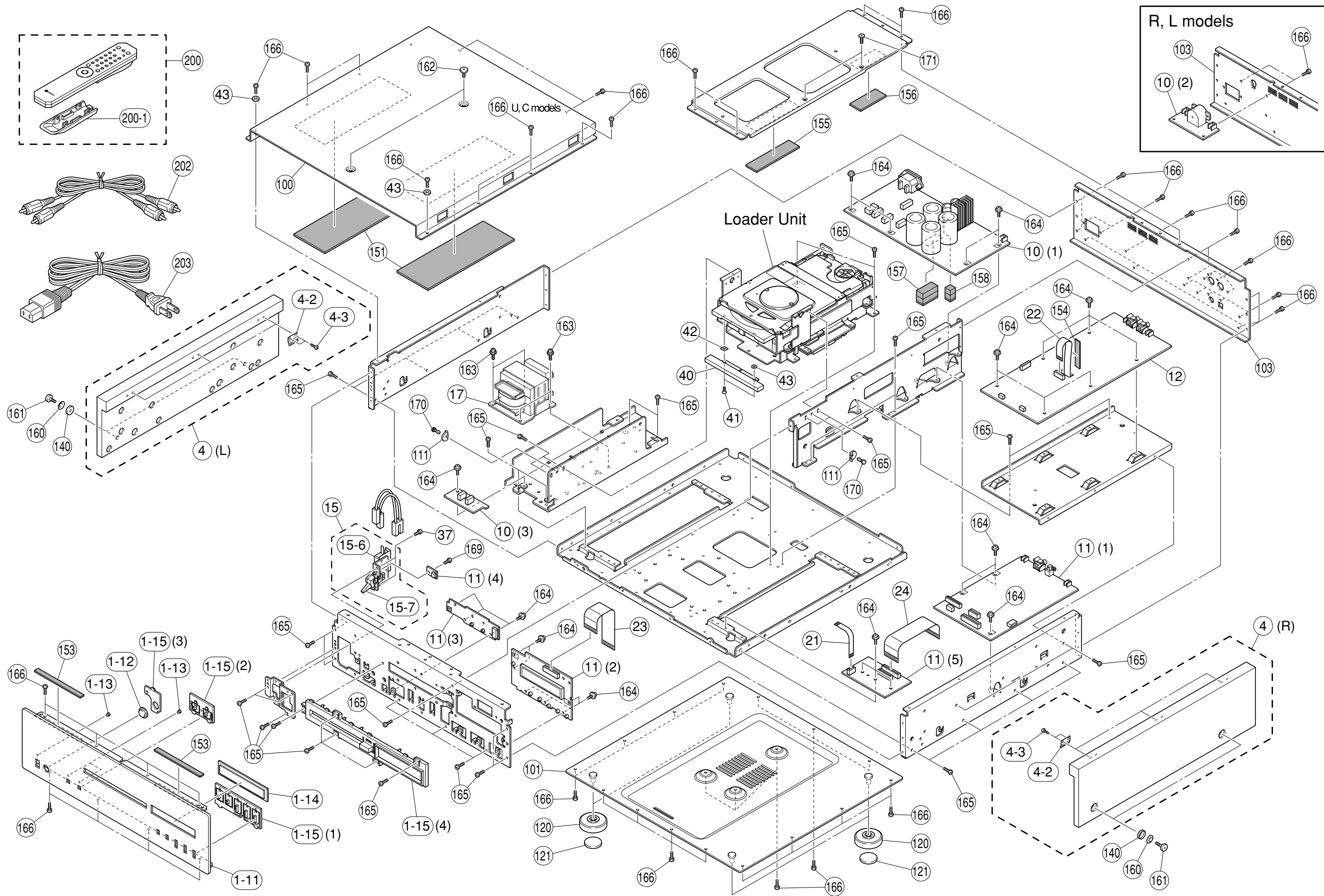

Ref No.	Part No.	Description	Remarks	Markets	部 品 名	ランク
*	1-11	WK854900	FRONT PANEL	BL	フロントパネル	
*	1-11	WK854800	FRONT PANEL	SI	フロントパネル	
	1-12	WK863700	LENS RC	BL	レンズ RC	
	1-12	WK863600	LENS RC	SI	レンズ RC	
	1-13	WK849200	LENS LED		レンズLED	
	1-14	WK855500	WINDOW PANEL LID		ウインドウ	
	1-15	WK855400	SUB PANEL	BL	サブパネル	
	1-15	WK855300	SUB PANEL	SI	サブパネル	
*	4	AAX90160	PANEL SIDE ASS'Y		パネルサイドASSY	
*	4	AAX90150	PANEL SIDE ASS'Y		パネルサイドASSY	
	4-2	WK862400	SUPPORT SIDE		サポートサイド	
	4-3	WN069200	PAN HEAD TAPPING SCREW #1		ナベTPネジ	
			3.5x16 MFZN2B3			
*	10	WM129100	P.C.B. ASS'Y		PCB パワー	
*	10	WM129200	P.C.B. ASS'Y		PCB パワー	
*	10	WM129300	P.C.B. ASS'Y		PCB パワー	
*	10	WM129400	P.C.B. ASS'Y		PCB パワー	
*	10	WM129500	P.C.B. ASS'Y		PCB パワー	
	11	WM129600	P.C.B. ASS'Y		PCB DIGITAL	
*	12	WM128100	P.C.B. ASS'Y		PCB AUDIO	
*	12	WM128200	P.C.B. ASS'Y		PCB AUDIO	
*	12	WM128300	P.C.B. ASS'Y		PCB AUDIO	
	15	WM082000	POWER SWITCH UNIT	BL	パワーSWユニット	
	15	WM081100	POWER SWITCH UNIT	SI	パワーSWユニット	
	15-6	WM098600	SWITCH MICRO		マイクロスイッチ	
	15-7	WK897100	LEVER POWER	BL	レバー POWER	
	15-7	WN508700	LEVER POWER	SI	レバー POWER	
*	17	X9720A00	POWER TRANSFORMER		電源トランス	
*	17	X9721A00	POWER TRANSFORMER		電源トランス	
*	17	X9722A00	POWER TRANSFORMER		電源トランス	
*	17	X9723A00	POWER TRANSFORMER		電源トランス	
*	17	X9725A00	POWER TRANSFORMER		電源トランス	
*	17	X9724A00	POWER TRANSFORMER		電源トランス	
	21	WM099700	FLEXIBLE FLAT CABLE		カード電線	
	22	WM099800	FLEXIBLE FLAT CABLE		カード電線	
	23	WM100000	FLEXIBLE FLAT CABLE		カード電線	
	24	WM100100	FLEXIBLE FLAT CABLE		カード電線	
	37	WF304200	BIND HEAD S-TIGHT SCREW		バインドSタイトネジ	01
	40	WK855200	LID	BL	リッド	
	40	WK855100	LID	SI	リッド	
	41	WG489600	FLAT HEAD SCREW		皿小ネジ	
	42	WN075800	WASHER LID A		ワッシャーLID A	
	43	WN075900	WASHER LID B		ワッシャーLID B	
	100	WK863900	TOP COVER	BL	トップカバー	
	100	WK863800	TOP COVER	SI	トップカバー	
	101	WK864100	BOTTOM COVER		ボトムカバー	
*	103	WK854300	REAR PANEL		リヤパネル	
*	103	WK853500	REAR PANEL		リヤパネル	
*	103	WK853600	REAR PANEL		リヤパネル	
*	103	WK853700	REAR PANEL		リヤパネル	
*	103	WK853800	REAR PANEL		リヤパネル	
*	103	WK853900	REAR PANEL		リヤパネル	
*	103	WK854000	REAR PANEL		リヤパネル	
*	103	WK854200	REAR PANEL		リヤパネル	
	111	WN570600	SUPPORT F		サポートF	
*	120	WN515400	LEG		レッグ	
			D45 t=19			

* New Parts * 新規部品

Ref No.	Part No.	Description	Remarks	Markets	部 品 名	ランク
*	121	WM026000	SHEET LEG		シート レッグ	
	140	WM026900	WASHER SIDE	BL	ワッシャーサイド	
	140	WK858600	WASHER SIDE	SI	ワッシャーサイド	
	151	WA207100	DAMPER		ダンパー	
	153	WN089800	DAMPER FRONT		ダンパーフロント	
	154	WN440100	DAMPER		ダンパー	
	155	WN494500	DAMPER		ダンパー	
	156	WN563000	DAMPER		ダンパー	
	157	WN563100	DAMPER		ダンパー	
	158	WN663900	DAMPER		ダンパー	
	160	WN426000	CONED DISC SPRING L		サラバネ L	
	161	WM026800	SCREW FLAT	BL	スクリュー フラット	
	161	WK864500	SCREW FLAT	SI	スクリュー フラット	
	162	VK522100	SPECIAL S-TIGHT SCREW	BL	化粧ネジSタイト	01
	162	VZ893000	SPECIAL S-TIGHT SCREW	SI	化粧ネジSタイト	02
	163	WE774700	BIND HEAD S-TIGHT SCREW		バインドSタイトネジ	01
	164	VT669300	PW HEAD B-TIGHT SCREW		PWヘッドBタイトネジ	01
	165	WE774300	BIND HEAD B-TIGHT SCREW		バインドBタイトネジ	01
	166	WE774100	BIND HEAD BONDING B-T. SCREW		ボンディングBタイトネジ	01
	169	WE774000	BIND HEAD SCREW		バインド小ネジ	01
	170	VQ368500	PUSH RIVET		プッシュリベット	01
	171	WG156300	FLAT HEAD B-TIGHT SCREW		皿Bタイトネジ	01
			ACCESSORIES		付属品	
	200	WM438000	REMOTE CONTROL		リモコン	
	200-1	AAX87780	BATTERY COVER		電池蓋	
	202	V6509000	AUDIO PIN CABLE		ステレオピンケーブル	04
	203	WA642300	POWER CABLE		電源コード	07
	203	V7704800	POWER CABLE		電源コード	05
	203	WK391000	POWER CABLE		電源コード	
	203	V9358400	POWER CABLE		電源コード	05
	203	WH641300	POWER CABLE		電源コード	
	203	WB750900	POWER CABLE		電源コード	07
	203	WK992000	POWER CABLE		電源コード	
	203	V7704900	POWER CABLE		電源コード	06
			BATTERY		単3乾電池	
			R6, AA, UM-3 2pcs			
			SERVICE TOOLS		サービス用部品	
	AAX88050	RS232C CONVERSION ADAPTER	with CABLE(8P,P=1.25)	CDS2000ADAPTER	RS232C変換アダプタ	
	MF112450	FLEXIBLE FLAT CABLE	12P 450mm P=1.25		カード電線 C&C	03
	AAX89650	GREASE	28.2g/20cc PN-397	GYA1001	グリス	

* New Parts * 新規部品

• LOADER UNIT

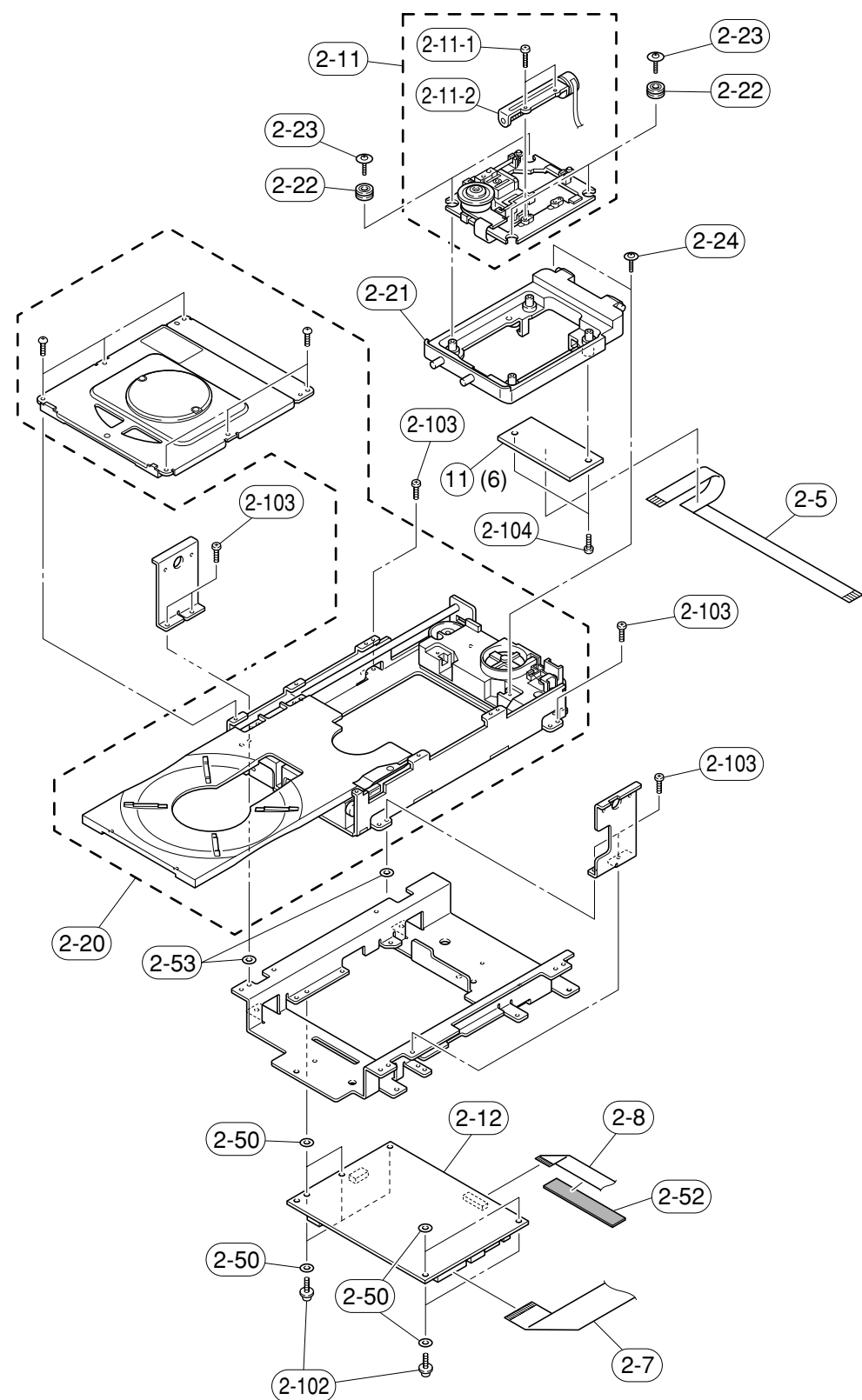

Ref No.	Part No.	Description	Remarks	Markets	部品名	ランク
2-5	WK899500	FLEXIBLE FLAT CABLE	24P 240mm P=0.5		カード電線	
2-7	WM099500	FLEXIBLE FLAT CABLE	29P 190mm P=1		カード電線	
2-8	WM099600	FLEXIBLE FLAT CABLE	17P 170mm P=1		カード電線	
2-11	WK823500	DVD TRAVERSE MECHANISM	DB-VTV733		DVDトラバースメカ	
2-11-1	AAX84090	STEPPER SCREW	R7C	DBA1205	ステッパネジ	
2-11-2	AAX84100	STEPPING MOTOR	VK1	DMX1201	ステッピングモーター	
2-12	X9062A00	MODULE BOARD	DB-APB101		モジュール基板	
2-20	WK897600	LOADER MECHANISM ASS'Y	YVCL-1		ローダーメカASSY	
2-21	WK896000	HOLDER PU SA-CD			ホルダーPU/SA-CD	04
2-22	WK896200	DAMPER SA-CD			ダンパーSA-CD	
2-23	WK891700	FLAT HEAD P-TIGHT SCREW	2x8 MFN133		皿Pタイトネジ	
2-24	WK891600	PW HEAD P-TIGHT SCREW	2x7 MFN133		PWPタイトネジ	
2-50	WN075800	WASHER LID A			ワッシャーLID A	
2-52	WN440100	DAMPER	15x80 t=2		ダンパー	
2-53	WN075900	WASHER LID B			ワッシャーLID B	
2-102	VT669300	PW HEAD B-TIGHT SCREW	3x8-8 MFC2		PWヘッドBタイトネジ	01
2-103	WE774300	BIND HEAD B-TIGHT SCREW	3x8 MFZN2W3		バインドBタイトネジ	01
2-104	WE961700	BIND HEAD B-TIGHT SCREW	2.6x8 MFZN2B3		バインドBタイトネジ	01
11	WM129600	P.C.B. ASS'Y	DIGITAL		PCB DIGITAL	

■ REMOTE CONTROL

• SCHEMATIC DIAGRAM

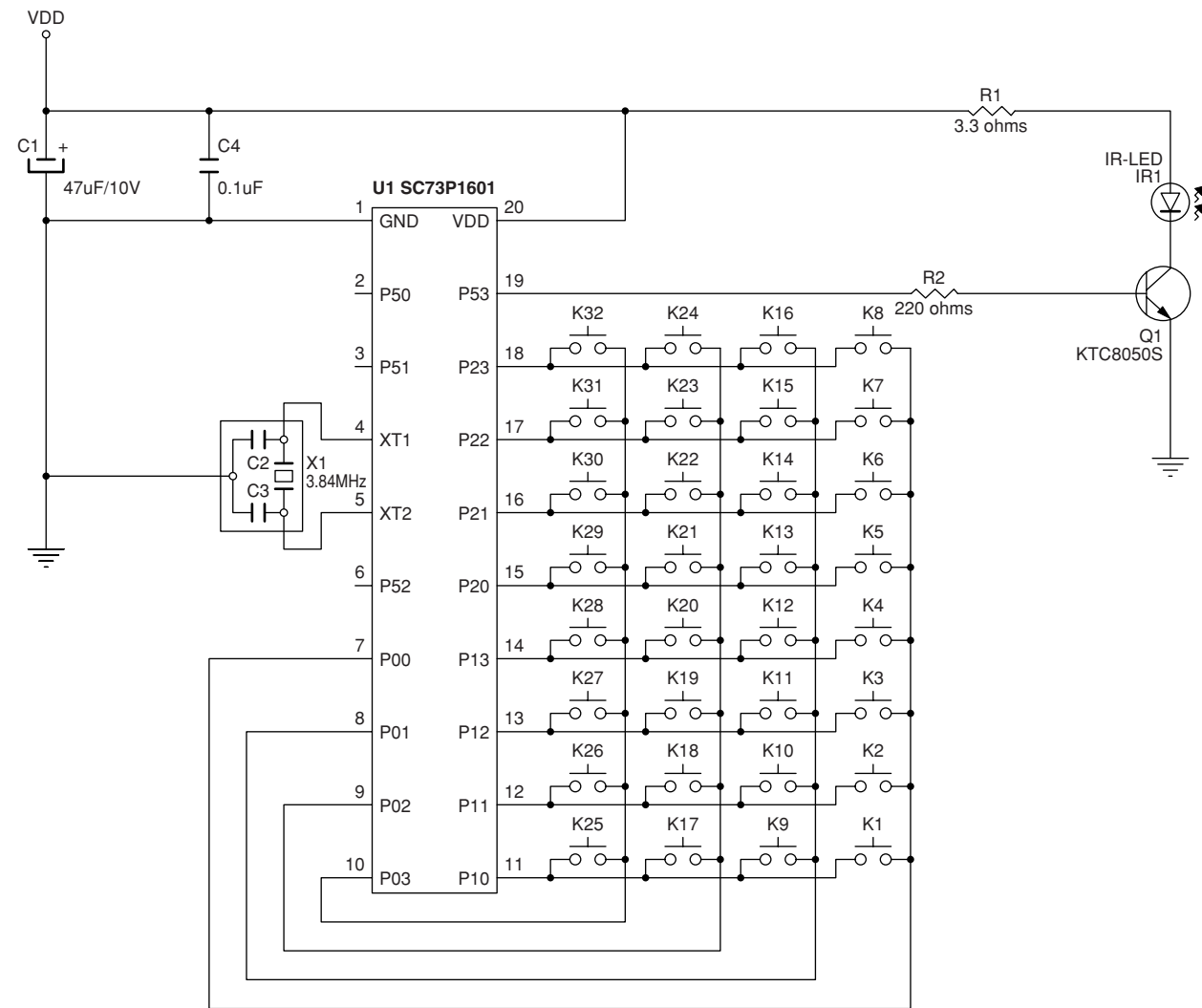

• PANEL

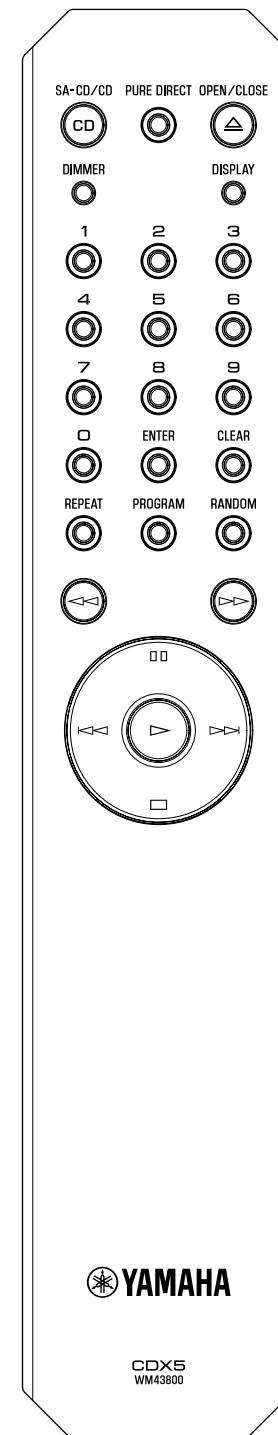

• KEY LAYOUT

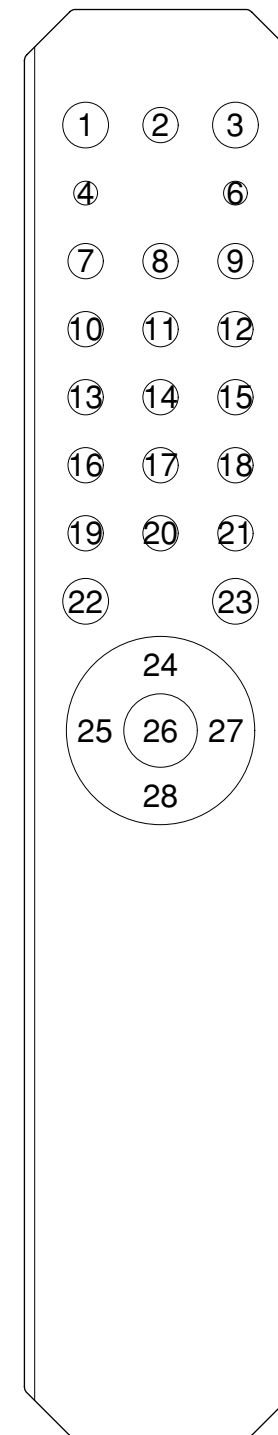

• KEY CODE

No.	Customer code	Data code	Function
1	79	6D	SA-CD/CD
2	79	6E	PURE DIRECT
3	79	01	OPEN/CLOSE
4	79	54	DIMMER
5	-	-	-
6	79	0A	DISPLAY
7	79	11	1
8	79	12	2
9	79	13	3
10	79	14	4
11	79	15	5
12	79	16	6
13	79	17	7
14	79	18	8
15	79	19	9
16	79	10	0
17	79	3F	ENTER
18	79	0D	CLEAR
19	79	08	REPEAT
20	79	0C	PROGRAM
21	79	1B	RANDOM
22	79	05	◀ (SEARCH-)
23	79	06	▶ (SEARCH+)
24	79	55	⏸ (PAUSE)
25	79	04	⏮ (SKIP-)
26	79	02	▶ (PLAY)
27	79	07	⏭ (SKIP+)
28	79	56	■ (STOP)

CD-S1000

